

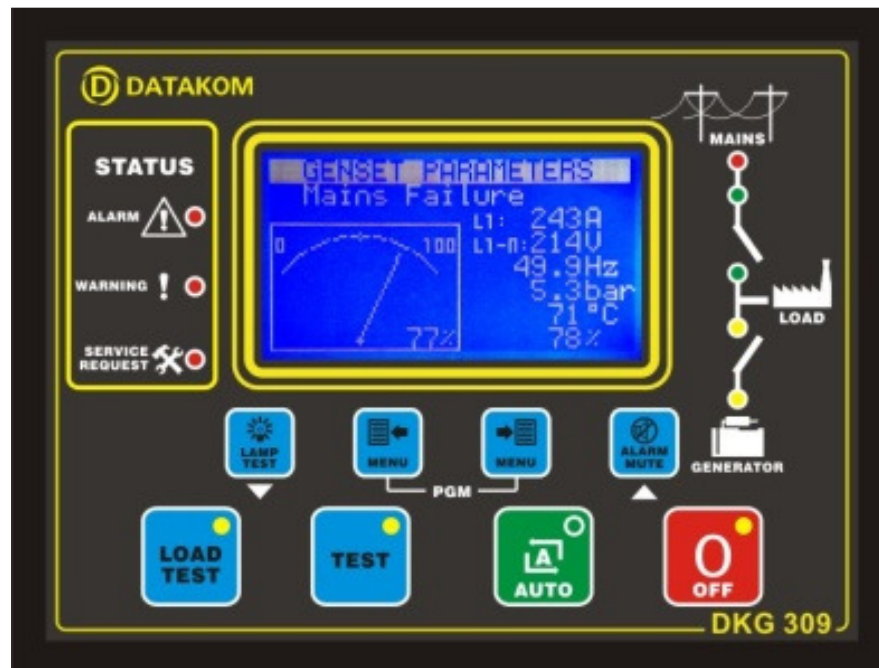

Tel: +90-216-466 84 60
 Fax: +90-216 364 65 65
 datakom@datakom.com.tr
 http://www.datakom.com.tr

DKG-309 AUTOMATIC MAINS FAILURE UNIT



FEATURES

Automatic mains failure
 Engine control
 Generator protection
 Built in alarms and warning
 Manual control enabled
 J1939 engine monitoring and control port
 J1939 ECU warnings displayed as text
 Dual genset mutual standby operation
 Load shedding, dummy load
 Gas engine support
 Engine idle speed control
 3 phase mains voltage inputs
 3 phase genset voltage inputs
 3 phase genset CT inputs
 Engine oil pressure measurement
 Engine coolant temperature measurement
 Fuel level measurement
 Genset active power measurement
 Genset power factor measurement
 Engine rpm display
 Periodic maintenance request indicator
 Daily / weekly / monthly exerciser
 Engine hours counter
 Event logging with date-time stamp and complete measurement values
 Stores last 250 events
 Statistical counters
 Battery backed-up real time clock
 Weekly operation schedule programs
 Programmable parameters

All parameters field adjustable
 Return to factory settings enabled
 RS-232 serial port
 Firmware downloadable from serial port
 Free MS-Windows Remote monitoring SW:
 -local and modem connection
 -monitoring, download of parameters
 -networking via modems
 GSM and PSTN modem support
 GSM-SMS sending in case of alarm
 Modem call in case of alarm
 MODBUS communication
 128x64 blue graphic LCD display
 Triple language support
 Customer logo display capability
 Configurable analogue inputs: 3
 Configurable digital inputs: 8
 Configurable relay outputs: 2
 Total relay outputs: 6
 Output expansion capability
 Remote Start operation available
 Mains simulation input
 Engine Idle speed control
 Internal buzzer for audible warning
 Survives cranking dropouts
 Sealed front panel
 Plug-in connection system for easy replacement
 Small dimensions (165x125x48mm)
 Low cost

TABLE OF CONTENTS**Section**

- 1. INSTALLATION**
 - 1.1. Introduction to the Control Panel
 - 1.2. Mounting the Unit
 - 1.3. Wiring the Unit
- 2. INPUTS AND OUTPUTS**
- 3. DISPLAYS**
 - 3.1. Led Displays
 - 3.2. Language Selection
 - 3.3. Digital Displays
- 4. ALARMS AND WARNINGS**
- 5. MODES OF OPERATION**
- 6. OTHER FEATURES**
 - 6.1. Remote start operation
 - 6.2. Sender type selection
 - 6.3. Engine heating operation
 - 6.4. Engine Idle Speed Operation
 - 6.5. Engine Block Heater
 - 6.6. Fuel Pump Control
 - 6.7. Mains Simulation
 - 6.8. Delayed Mains Simulation, Battery Charging
 - 6.9. Dual Genset Mutual Standby Operation
 - 6.10. Service Request Display
 - 6.11. Engine Hours Meter
 - 6.12. Date-Time Display
 - 6.13. Display of Software Version
 - 6.14. Modem connection
 - 6.15. SMS message sending
 - 6.16. Remote Monitoring and Programming
 - 6.17. Automatic Exerciser
 - 6.18. Resuming to factory set parameters
 - 6.19. Gas engine fuel solenoid control
 - 6.20. Changing the Default Engine Speed in Volvo Engines
 - 6.21. Load Shedding / Dummy Load
 - 6.22. Firmware Update
- 7. -**
- 8. MODBUS COMMUNICATION**
- 9. WEEKLY OPERATION SCHEDULE**
- 10. EVENT LOGGING**
- 11. STATISTICAL COUNTERS**
- 12. MAINTENANCE**
- 13. PROGRAMMING**
- 14. TROUBLESHOOTING**
- 15. DECLARATION OF CONFORMITY**
- 16. TECHNICAL SPECIFICATIONS**
- 17. CONNECTION DIAGRAM**

1. INSTALLATION

1.1 Introduction to the Control Panel

The unit is a control and protection panel used in gensets. It shows the measured values on its displays. The unit is designed to provide user friendliness for both the installer and the user. Programming is usually unnecessary, as the factory settings have been carefully selected to fit most applications. However programmable parameters allow the complete control over the generating set. Programmed parameters are stored in a Non Volatile Memory and thus all information is retained even in the event of complete loss of power.

The measured parameters are:

- Mains voltage phase L1 to neutral
- Mains voltage phase L2 to neutral
- Mains voltage phase L3 to neutral
- Mains voltage phase L1-L2
- Mains voltage phase L2-L3
- Mains voltage phase L3-L1
- Gen voltage phase L1 to neutral
- Gen voltage phase L2 to neutral
- Gen voltage phase L3 to neutral
- Gen voltage phase L1-L2
- Gen voltage phase L2-L3
- Gen voltage phase L3-L1
- Gen current phase L1
- Gen current phase L2
- Gen current phase L3
- Gen frequency
- Engine speed (rpm)
- Gen total KW
- Gen total $\cos\Phi$
- Battery voltage,
- Coolant temperature
- Oil pressure
- Fuel level
- Gen frequency
- Mains frequency

1.2 Mounting the Unit

The unit is designed for panel mounting. The user should not be able to access parts of the unit other than the front panel.

Mount the unit on a flat, vertical surface. The unit fits into a standard panel meter opening of 151x111 millimeters. Before mounting, remove the mounting brackets and connectors from the unit, then pass the unit through the mounting opening. The unit will be maintained in its position by the mounting brackets spring.



Engine body must be grounded for correct operation of the unit, otherwise incorrect voltage and frequency measurements may occur.

The output of the current transformers shall be 5 Amperes. The input current rating of the current transformers may be selected as needed (between 10/5 and 9000/5 amps). Current transformer outputs shall be connected by separate cable pairs from each transformer, to related inputs. Never use common terminals or grounding. The power rating of the transformer should be at least 5 VA. It is recommended to use 1% precision transformers.

If analogue senders (e.g. temperature, oil pressure or fuel level) are connected to the unit, it is not possible to use auxiliary displays, otherwise the unit may be damaged. If temperature or oil pressure or fuel level displays are already present on the generator control panel, do not connect the senders to the unit. The unit is factory programmed for VDO type senders. However different types of senders are selectable via programming menu. Please check the programming section.

The programmable digital inputs are compatible with both 'normally open' and 'normally closed' contacts, switching either to **BAT-** or **BAT+**.

The charge alternator connection terminal provides also the excitation current, thus it is not necessary to use an external charge lamp.

1.3 Wiring the Unit



WARNING: THE UNIT IS NOT FUSED.

Use external fuses for Mains phases: L1,L2,L3, Generator phase: L1,L2,L3, Battery positive: BAT(+). Install the fuses as nearly as possible to the unit in a place easily accessible for the user. The fuse rating should be 6 Amps.



WARNING: ELECTRICITY CAN KILL
ALWAYS disconnect the power BEFORE connecting the unit.

- 1) **ALWAYS remove the plug connectors when inserting wires with a screwdriver.**
- 2) **An appropriate and readily accessible set of disconnection devices (e.g. automatic fuses) MUST be provided as part of the installation.**
- 3) **The building mains supply MUST incorporate appropriate short-circuit backup protection (e.g. a fuse or circuit breaker) of High Breaking Capacity (HBC, at least 1500A).**
- 4) **Use cables of adequate current carrying capacity (at least 0.75mm²) and temperature range.**

2. INPUTS AND OUTPUTS

RS-232 SERIAL PORT: This connector provides serial data input and output for various purposes like remote monitoring and remote programming.

EXTENSION CONNECTOR: This connector is intended for the connection to output extension modules. The optional relay extension module provides 8 programmable 16A relay outputs. The unit allows the use of up to 2 I/O extension modules.

Term	Function	Technical data	Description
1	GENERATOR CONTACTOR	Relay output, 16A-AC	This output provides energy to the generator contactor. If the generator phases do not have acceptable voltage or frequency values, the generator contactor will be de-energized. In order to provide extra security, the normally closed contact of the mains contactor should be serially connected to this output.
2	GEN-L1	Generator phase inputs, 0-300V-AC	Connect the generator phases to these inputs. The generator phase voltages upper and lower limits are programmable.
3	GEN-L2		
4	GEN-L3		
5	GENERATOR NEUTRAL	Input, 0-300V-AC	Neutral terminal for the generator phases.
6	MAINS NEUTRAL	Input, 0-300V-AC	Neutral terminal for the mains phases.
7	MAINS-L3	Mains phase inputs, 0-300V-AC	Connect the mains phases to these inputs. The mains voltages upper and lower limits are programmable.
8	MAINS-L2		
9	MAINS-L1		
10	MAINS CONTACTOR	Relay output, 16A-AC	This output provides energy to the mains contactor. If the mains phases do not have acceptable voltages, the mains contactor will be de-energized. In order to provide extra security, the normally closed contact of the generator contactor should be serially connected to this output.
11	GROUND	0 VDC	Power supply negative connection.
12	BATTERY POSITIVE	+12 or 24VDC	The positive terminal of the DC Supply shall be connected to this terminal. The unit operates on both 12V and 24V battery systems.
13	FUEL LEVEL SENDER	Input, 0-5000 ohms	No connection to this terminal.
14	OIL PRESSURE SENDER	Input, 0-5000 ohms	Analogue oil pressure sender connection. Do not connect the sender to other devices. The input has programmable characteristics and connects to any kind of sender.
15	COOLANT TEMP. SENDER	Input, 0-5000 ohms	Analogue high temperature sender connection. Do not connect the sender to other devices. The input has programmable characteristics and connects to any kind of sender.

Term	Function	Technical data	Description
16	CHARGE	Input and output	Connect the charge alternator's D+ terminal to this terminal. This terminal will supply the excitation current and measure the voltage of the charge alternator.
17	RELAY-2 (HORN RELAY)	Output 10A/28VDC	This relay has programmable function, selectable from a list.
18	RELAY-1 (STOP RELAY)	Output 10A/28VDC	This relay has programmable function, selectable from a list.
19	START RELAY	Output 10A/28VDC	This relay controls the engine cranking.
20	FUEL RELAY	Output 10A/28VDC	This relay is used for fuel solenoid control. It is internally connected to terminal 16 for supplying the charge alternator's excitation current.
21	EMERGENCY STOP	Digital inputs	These inputs have programmable characteristics selected via the program menu. Each input may be driven by a 'normally closed' or 'normally open' contact, switching either battery+ or battery-. The effect of the switch is also selectable from a list. See PROGRAMMING section for more details.
22	SPARE-2		
23	PROGRAM LOCK		
24	SPARE-1		
25	COOLANT LEVEL		
26	HIGH TEMP		
27	LOW OIL PRESSURE		
28	RECTIFIER FAIL		
29	CURR_1+	Current transformer inputs, 5A-AC	Connect the generator current transformer terminals to these inputs. Do not connect the same current transformer to other instruments otherwise a unit fault will occur. Connect each terminal of the transformer to the unit's related terminal. Do not use common terminals. Do not use grounding. Correct polarity of connection is vital. If the measured power is negative, then change the polarity of each 3 current transformers. The rating of the transformers should be the same for each of the 3 phases. The secondary winding rating shall be 5 Amperes. (For ex. 200/5 Amps).
30	CURR_1-		
31	CURR_2+		
32	CURR_2-		
33	CURR_3+		
34	CURR_3-		

3. DISPLAYS

3.1 Led Displays

The unit has 12 LEDs, divided in 3 groups:

- Group 1:** Operating mode: This group indicates the genset function.
- Group 2:** Mimic diagram: This group indicates the current status of the mains and genset voltages and contactors.
- Group 3:** Warnings and alarms: This group indicates the existence of abnormal conditions encountered during operation.

Function	Color	Description
MAINS ON	Green	The LED will turn on when all 3 mains phase voltages are within the limits.
MAINS OFF	Red	The LED will turn on when at least one of the mains phase voltages is outside limits.
LOAD MAINS	Green	It turns on when the mains contactor is activated.
LOAD GENERATOR	Yellow	It turns on when the generator contactor is activated.
GENERATOR	Yellow	The LED will flash when the engine is running. It will turn on steadily when all 3 generator phase voltages are within the programmed limits.
LOAD TEST	Yellow	It turns on when the related operation mode is selected. One of these LEDs is always on and indicates which operation mode is selected.
TEST	Yellow	
OFF	Yellow	
AUTO	Green	If the operation of the genset is disabled by the weekly operation schedule , then the AUTO led will flash.
GENERATOR RUN	Yellow	It turns on when the related pushbuttons are pressed in MANUAL mode.
GENERATOR STOP	Yellow	
ALARM	Red	If a fault condition resulting to the engine shutdown has occurred, the alarm led turns on steadily. If a loaddump condition occurs, this led will flash. Alarms work on a first occurring basis. The occurrence of a fault will disable other faults of lower or equal priority.
WARNING	Red	If a warning condition has occurred, this led turns on steadily. The warnings work on a first occurring basis. The occurrence of a warning will disable other warnings, however shutdown and loaddump alarms are still allowed.
SERVICE REQUEST	Red	Engine periodic maintenance request indicator. It turns on when the preset engine hours or time duration after previous service has elapsed.

3.2 Language Selection

The unit is able to display information in 3 languages. Language selection is made through program parameter CONTROLLER CONFIGURATION > LANGUAGE SELECTION. Below selections are available:

- 0: English language
- 1: Turkish language
- 2: Chinese language
- 3: ask selection at power-up

If language is set to 3, below screen will come at power on:

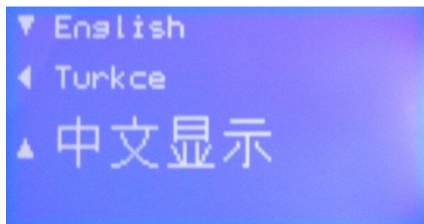

Left / Up / Down arrow pushbuttons will select the screen language. The language will be asked everytime power is turned on.

With selections of 0,1,2 this screen will not appear and the selected language is enabled.

3.3 Digital Display

The unit has a graphical 128x64 pixel LCD display. It shows:

- Measured parameters,
- The company logo,
- The alarm list
- Software version and date-time information,
- Statistical counters,
- Event records,
- Program parameters.

Navigation between different screens is made with the ◀MENU and MENU▶ buttons. Each depression of the MENU▶ button switches the display to the next screen. Each depression of the ◀MENU button switches the display to the previous screen.

During operation, the unit will switch automatically between different screens, displaying always the most important parameters for the current operating status.

If an alarm or warning occurs during operation, in other than programming mode, the display will automatically switch to **ALARM LIST** position. The ◀MENU or MENU▶ buttons will not function. To enable display navigation and mute the internal buzzer, press **ALARM MUTE** button first. If there is more than one alarm, the next alarm is displayed by pressing the ▼ button. Thus all existing alarms can be scanned. '**END OF ALARM LIST**' will be displayed when there is no more alarm to display.

The display has a **backlight** illumination feature. The **backlight** turns on with the depression of any button or when the genset runs. It turns off after 4 hours to allow power economy.

Screen	Description	Contents
1	Mains parameters (phase to neutral)	Genset status Mains Volts L1, Mains Volts L2, Mains Volts L3, Mains Frequency Battery Voltage Coolant Temperature
2	Mains parameters (phase to phase)	Genset status Mains Volts L1-L2, Mains Volts L2-L3, Mains Volts L3-L1, Mains Frequency Battery Voltage Coolant Temperature
3	Genset parameters (phase to neutral)	Genset status Genset Current L1, Genset Current L2, Genset Current L3, Genset Frequency Genset Active Power (KW) Genset Volts L1
4	Genset parameters (phase to phase)	Genset status Genset Current L1, Genset Current L2, Genset Current L3, Genset Frequency Genset Active Power (KW) Genset Volts L1-L2
5	Engine parameters	Genset status Oil Pressure, Coolant Temperature, Fuel Level, Engine rpm Battery Voltage
6	Complete Genset parameters (phase to neutral)	Genset status Genset Volts L1, Genset Volts L2, Genset Volts L3 Genset Current L1, Genset Current L2, Genset Current L3, Genset Frequency, Oil Pressure Genset Active Power (KW), Coolant Temperature Genset power factor, Fuel Level Engine rpm, Battery Voltage
7	Complete Genset parameters (phase to phase)	Genset status Genset Volts L1-L2, Genset Volts L2-L3, Genset Volts L3-L1 Genset Current L1, Genset Current L2, Genset Current L3 Genset Frequency, Oil Pressure Genset Active Power (KW), Coolant Temperature Genset power factor, Fuel Level Engine rpm, Battery Voltage
8	Graphical Genset parameters (phase to neutral)	Genset status Genset Active Power (%), Genset Current L1 Genset Volts L1 Genset Frequency Oil Pressure Coolant Temperature Fuel Level
9	Graphical Genset parameters (phase to phase)	Genset status Genset Active Power (%), Genset Current L1 Genset Volts L1-L2 Genset Frequency Oil Pressure Coolant Temperature Fuel Level

Screen	Description	Contents
10	Company Logo	
11	Alarm List	If no alarm exists, 'END OF ALARM LIST' will be displayed. Existing alarms, load_dumps, warnings will be displayed as one screen for each entry. Switching to the next entry will be made with the ▼ button.
12	Date-Time, Software Version	Date and time. Operating software version.
13	Statistical Counters 1 / 3	Engine Hours Run Total Genset Active Power (KW-h)
14	Statistical Counters 2 / 3	Engine Hours to Service Time to Service
15	Statistical Counters 3 / 3	Total Engine Cranks Total Engine Runs
16	Event Records	The unit provides information about last 100 events, starting from the most recent one. Please review chapter 10 for detailed information about event logging.
17	Test Screen	This screen is designed for unit testing. It is not used in normal operation.

4. ALARMS AND WARNINGS

Alarms indicate an abnormal situation in the generating set are divided into 3 priority levels:

- 1- **ALARMS:** These are the most important fault conditions and cause:
 - The related alarm led to be on steadily,
 - The genset contactor to be released immediately,
 - The engine to be stopped immediately,
 - The **Horn, Alarm, Alarm+Load_dump** and **Alarm+Load_dump+Warning** relays output to operate, (if selected via programming menu)

- 2- **LOAD_DUMPS:** These fault conditions cause:
 - The related alarm led to be on steadily,
 - The genset contactor to be released immediately,
 - The engine to be stopped after Cooldown period,
 - The **Horn, Alarm+Load_dump** and **Alarm+Load_dump+Warning** relays output to operate, (if selected via programming menu)

- 3- **WARNINGS:** These conditions cause:
 - The related alarm led to flash,
 - The **Horn** and **Alarm+Load_dump+Warning** relay outputs to operate, (if selected via programming menu)

If the ALARM MUTE button is pressed, the Horn relay output will be deactivated; however the existing alarms will persist and disable the operation of the genset.

Alarms operate in a first occurring basis:

- If an alarm or load_dump is present, following alarms, load_dumps and warnings will not be accepted,
- If a warning is present, following warnings will not be accepted.

Alarms may be of LATCHING type following programming. For latching alarms, even if the alarm condition is removed, the alarms will stay on and disable the operation of the genset. The existing **alarms may be canceled** by pressing one of the operating mode buttons (**LOAD TEST / TEST / OFF / AUTO**).

Most of the alarms have programmable trip levels. See the programming chapter for adjustable alarm limits.

LOW OIL PRESSURE: Set if a signal is detected at the Low Oil Pressure Switch input or the oil pressure value measured from the sender is below the programmed limit. Warning and alarm limits are separately programmable for the oil pressure sender input. This fault will be monitored with **Holdoff Timer** delay after the engine is running. Also if the oil pressure switch is open at the beginning of a start attempt, then the engine will not be started and "**Oil Pressure Exists!**" information is displayed. When the oil pressure switch closes, normal operation will be resumed.

HIGH TEMPERATURE: Set if a signal is detected at the High Temperature Switch input or the coolant temperature value measured from the sender is above the programmed limit. Warning and alarm limits are separately programmable for the temperature sender input.

LOW FUEL: Set if a signal is detected at the low fuel level input or the the fuel level measured from the sender is below the programmed limit. Warning and alarm limits are separately programmable for the fuel level sender input.

LOW COOLANT LEVEL: Set if a signal is detected at the low coolant level input.

RECTIFIER FAIL: Set if a signal is detected at the rectifier fail input. This input is only monitored when mains voltages are present.

EMERGENCY STOP: Set if a signal is detected at the emergency stop input.

SPARE-1 / SPARE-2: Set if a signal is detected from the related spare fault input.

LOW FREQUENCY / HIGH FREQUENCY: Set if the generator frequency is outside programmed limits. These faults will be monitored with **Holdoff Timer** delay after the engine is running. Low and high limits for warning and alarm are separately programmable.

START FAIL (alarm): Set if the engine is not running after programmed number of start attempts.

STOP FAIL (warning): Set if the engine has not stopped before the expiration of the **Stop Timer**.

OVERLOAD (load dump): Set if at least one of the genset phase currents goes over the **Overcurrent Limit** for **Overload Timer**. If currents goes below the limit before expiration of the timer then no alarm will be set.

EXCESS POWER (load dump): Set if the genset power (KW) supplied to the load goes over the **Excess Power** limit for **Overload Timer**. If the power goes below the limit before expiration of the timer then no alarm will be set.

GENSET LOW VOLTAGE: Set if any of the generator phase voltages goes outside programmed limits for **Overload Timer**. This fault will be monitored with **holdoff timer** delay after the engine is running.

GENSET HIGH VOLTAGE: Set if any of the generator phase voltages goes outside programmed limits for **Overload Timer**. This fault will be monitored with **holdoff timer** delay after the engine is running.

LOW BATTERY VOLTAGE (warning): Set if the battery voltage goes below the programmed limit. During engine cranking this fault is not monitored.

HIGH BATTERY VOLTAGE: Set if the battery voltage goes above programmed limits. Both warning and alarm levels for high battery voltage are programmable.

CHARGE: Set if a charge alternator failure (or broken belt) occurs. This fault condition may result to a **warning** or **alarm** following programming.

ECU FAIL (warning): Set when an engine fault code is received from the ECU of the electronic engine. This fault will not cause an engine stop. If necessary, the engine will be stopped by the ECU.

ECU FAIL (alarm): Set if no information has been received during 3 seconds from the ECU of the electronic engine. This fault condition is only controlled if fuel is on.

MAINS PHASE ORDER FAIL (warning): Set if the mains phase order checking is enabled, mains phases are present and mains phase order is reversed.

5. MODES OF OPERATION

The modes of operation are selected by pushing the front panel keys. Changing the operation mode while the genset is running will result into a behavior suitable for the new operating mode. For example, if the LOAD TEST mode is selected when genset is running at TEST mode, then the genset will take the load.

OFF: In this mode, the mains contactor will be energized if mains phase voltages are within the programmed limits. The engine will be stopped.

AUTO: It is used for genset and mains automatic transfer. If at least one of the mains phase voltages is outside limits, the mains contactor will be deactivated.

The diesel will be started for programmed times after the preheat timer. When the engine runs, the crank relay will be immediately deactivated. The engine will run without load during engine heating period. After this, if alternator phase voltages and frequency are within limits, then the unit will wait for the generator contactor period and the generator contactor will be energized.

When all the mains phase voltages are within the limits, the engine will continue to run for the mains waiting period. At the end of this period the generator contactor is deactivated and the mains contactor will be energized. If a cooldown period is given, the generator will continue to run during cooldown period. At the end of the period, the fuel solenoid will be de-energized and the diesel will stop. The unit will be ready for the next mains failure.

If the operation of the genset is disabled by the **weekly schedule**, then the **AUTO** led will flash, and the operation of the genset will be as in the **OFF** mode.

TEST: It is used to test the generator when the mains are on, or keep the generator running in the emergency backup mode. The operation of the generator is similar to the AUTO mode, but the mains contactor will not be deactivated if the mains are not off. If the mains are off, mains contactor will be deactivated and the generator contactor will be activated. When the mains are on again, a changeover to the mains will be made, but the engine will be kept running unless another mode is selected. To stop the engine, select **AUTO** or **OFF** mode.

LOAD TEST: It is used to test the genset under load. Once this mode is selected, the engine will run and the load will be transferred to the genset. The genset will feed the load indefinitely unless another mode is selected.

6. OTHER FEATURES

6.1 Remote Start Operation

The unit offers the possibility of **REMOTE START** mode of operation. If the **Remote Start Operation** program parameter is set to **1** then the unit will enter to the Remote Start operation. The Remote Start signal should be connected to the **SPARE_2 (37)** input.

The REMOTE START signal may be a NO or NC contact, switching to either battery positive or battery negative. These selections are made using programming menu.

It is also necessary to set the **ACTION** program parameter of the **SPARE-2** input to **3** in order to prevent the alarms generated from this input.

In this mode the mains phases are not monitored. If the REMOTE START signal is present then the mains will be supposed to fail, inversely if the REMOTE START signal is absent, then mains voltages will be supposed to be present. The front panels mimic diagram's mains LEDs will reflect the status of the REMOTE START input.

6.2 Sender type Selection

The unit has the ability to adapt to any type of oil pressure and temperature senders. The commonly used standard sender characteristics are recorded in memory and selectable from a list. However non standard senders may also be used by entering their characteristics to the table.

Oil Pressure Sender Type Selection:

Selectable sender types are:

0: Sender characteristics are defined in **Sender Characteristics** table.

1: VDO 0-7 bars (10-180 ohms)

2: VDO 0-10 bars (10-180 ohms)

3: DATCON 0-7 bars (240-33 ohms)

4: DATCON 0-10 bars (240-33 ohms)

5: DATCON 0-7 bars (0-90 ohms)

6: DATCON 0-10 bars (0-90 ohms)

7: DATCON 0-7 bars (75-10 ohms)

Temperature Sender Selection:

Selectable sender types are:

0: Sender characteristics are defined in **Sender Characteristics** table.

1: VDO

2: DATCON DAH type

3: DATCON DAL type

Fuel Level Sender Selection:

The **Fuel Level Sender Ohms** is also programmable.

6.3 Engine Heating Operation

Especially on engines without a body heater, or with a failing one, it may be desired that the genset should not take the load before reaching a suitable temperature. The unit offers 2 different ways of engine heating.

1. Timer controlled heating:

This operation mode is selected when the **Engine Heating Method** parameter is set to **0**. In this mode, the engine will run during parameter **Engine Heating Timer**, and then the genset will take the load.

2. Timer and temperature controlled heating:

This operation mode is selected when the **Engine Heating Method** parameter is set to **1**. In this mode, at first the engine will run during parameter **Engine Heating Timer**, then it will continue to run until the measured coolant temperature reaches the limit defined in parameter **Engine Heating Temperature**. When the requested temperature is reached, the load will be transferred to the genset. This operation mode may be used as a backup to the engine body heater. If the engine body is warm the heating will be skipped.

6.4 Engine Idle Speed Operation

It may be required that the engine runs at the idle speed for a programmed duration for engine heating. The idle operation duration is adjusted with the parameter **Idle Speed Timer**. The idle speed will be set by the governor control unit of the engine.

Any of the spare relay outputs may be assigned as **IDLE output** using **Relay Definition** program parameters. Also relays on an extension module may be assigned to this function.

The Idle speed operation is performed both in engine start-up and cool-down sequences. Speed and voltage protections are disabled during idle speed operation.

6.5 Engine Block Heater

The unit is able to provide a relay output in order to drive the block heater resistor.

The temperature reference is the coolant temperature measured from the the analog sender input.

The block heater relay function may be assigned to spare relays using **Relay Definition** program parameters. Also relays on an extension module may be assigned to this function.

The engine body temperature limit is adjusted using the parameter **Engine Heating Temperature**. The same parameter is used for engine heating operation.

The relay will become active if the body temperature falls to 4 degrees below the limit set by **Engine Heating Temperature**. It turns off when the body temperature exceeds **Engine Heating Temperature**.

6.6 Fuel Pump Control

The unit is able to provide a relay output in order to drive the fuel pump motor. The fuel pump is used in order to transfer fuel from the large capacity main tank (if exists) to the genset daily tank which is generally integrated in the chassis and has a limited capacity.

The fuel level reference is measured through the analog fuel level sender. When the measured fuel level falls to 25 % the fuel pump relay output will operate. When the fuel level reaches 75 % the relay will turn off. Thus the chassis fuel tank level will be always kept between $\frac{1}{4}$ and $\frac{3}{4}$.

The fuel pump relay function may be assigned to spare relays using **Relay Definition** program parameters. Also relays on an extension module may be assigned to this function.

6.7 Mains Simulation

The unit offers an optional **SIMULATE MAINS** signal input. If the program parameter **Simulate Mains Operation** is set to **1** then the **SPARE_2 (37)** input will be used for mains simulation.

It is also necessary to set the **ACTION** program parameter of the **SPARE-2** input to **3** in order to prevent the alarms generated from this input.

The **SIMULATE MAINS** signal may be a NO or NC contact, switching to either battery positive or battery negative. These selections are made using the programming menu.

If the **Simulate Mains Operation** program parameter is set to **1** and the input signal is active, the mains phases are not monitored and supposed to be inside limits. This will prevent the genset from starting even in case of a mains failure. If the genset is running when the signal is applied, then usual Mains Waiting and Cooldown cycles will be performed before engine stop. When the **SIMULATE MAINS** signal is present, the front panels mimic diagram's mains LEDs will reflect the mains voltages as present.

When the signal is passive, the unit will revert to normal operation and monitor the mains voltage status.



The REMOTE START operation overrides SIMULATE MAINS operation. When both parameters “Remote Start Operation” and “Simulate Mains Operation” are set then REMOTE START operation mode is performed.

6.8 Delayed Mains Simulation, Battery Charging

The Delayed Mains Simulation feature is used in battery backed up telecom systems where batteries are able to supply the load during a certain period. The genset is requested to run only when battery voltage drops below the critical level. Once the engine runs, the rectifier system starts charging the batteries and the battery voltage goes up immediately. Thus the engine should continue to run a programmed period for effective charging. The critical battery voltage level will be detected by an external unit which provides the digital Simulate Mains signal for the genset control unit.

The unit offers an optional **SIMULATE MAINS** signal input. If the **Delayed Simulate Mains** program parameter is set to **1** then the **SPARE_2 (37)** input will be used for delayed mains simulation.

It is also necessary to set the **ACTION** program parameter of the **SPARE-2** input to **3** in order to prevent the alarms generated from this input.

The **SIMULATE MAINS** signal may be a NO or NC contact, switching to either battery positive or battery negative. These selections are made using the programming menu.

If the **Delayed Simulate Mains** program parameter is set to **1** and the input signal is active when the genset is not feeding the load, the mains phases are not monitored and supposed to be inside limits. This will prevent the genset from starting when the simulate mains signal is present (batteries charged). The genset will start when mains voltages are out of limits and the simulate mains signal not present.

If the genset is running when the signal is applied, then **MAINS SIMULATION** will be prevented during **Flashing Relay Timer** program parameter. After this, usual Mains Waiting and Cooldown cycles will be performed before engine stop. When the **SIMULATE MAINS** signal is present, the front panels mimic diagram's mains LEDs will reflect the mains voltages as present.

When the signal is passive, the unit will revert to normal operation and monitor the mains voltage status.



The REMOTE START operation overrides DELAYED SIMULATE MAINS operation. When both parameters “Remote Start Operation” and “Delayed Simulate Mains” are set then REMOTE START operation mode is performed.

6.9 Dual Genset Mutual Standby Operation

Dual genset intermittent operation consists of regular switching of the load between 2 gensets. The use of 2 gensets instead of one is due either to safety purposes in case of a genset failure or to a continuous operation requesting service stops.

The running period for each genset is adjustable using **Flashing Relay Timer** program parameter. If the time is adjusted as 0 hours, it will be actually set to 2 minutes for faster testing purposes.

A flashing relay output function is provided, based on the parameter **Flashing Relay Timer**. Each time the period programmed using **Flashing Relay Timer** elapses, the relay output will change position.

The flashing relay function may be assigned to spare relays using **Relay Definition** program parameters. Also relays on an extension module may be assigned to this function.

The dual genset intermittent operation uses also the **Mains Simulation** feature. Please review chapter 6.7 for a detailed explanation of this feature.



Please contact DATAKOM for a complete application manual.

6.10 Service Request Display

This led is designed to help the periodic maintenance of the genset to be made consistently. The periodic maintenance is basically carried out after a given engine hours (for example 200 hours), but even if this amount of engine hours is not fulfilled, it is performed after a given time limit (for example 12 months).



The SERVICE REQUEST led has no effect on the genset operation.

The unit has both programmable engine hours and maintenance time limit. The engine hours is programmable with 50-hour steps, the time limit is programmable with 1 month steps. If any of the programmed values is zero, this means that the parameter will not be used. For example a maintenance period of 0 months indicates that the unit will request maintenance only based on engine hours, there will be no time limit. If the engine hours is also selected as 0 hours this will mean that the SERVICE REQUEST display will be inoperative.

When the engine hours **OR** the time limit is over, the **SERVICE REQUEST** led (red) will start to flash and the service request relay function will be active.

The service request relay function may be assigned to spare relays using **Relay Definition** program parameters. Also relays on an extension module may be assigned to this function.



To turn off the SERVICE REQUEST led, and reset the service period, press together the ALARM MUTE and LAMP TEST keys for 5 seconds.

The remaining engine hours and the remaining time limit are kept stored in a non-volatile memory and are not affected from power supply failures.

The time and engine hours to service are displayed in the **STATISTICAL COUNTERS** menu.

6.11 Engine Hour Meter

The unit features a non-erasable incremental engine hour meter. The hour meter information is kept in a non-volatile memory and is not affected from power supply failures.

The engine hours may be displayed **STATISTICAL COUNTERS** menu.

6.12 Date & Time Display

The date & time display is provided for verification.

6.13 Software Version Display

Some additional features are installed within consecutive software releases. In order to be sure of the validity of the status of the unit, the software version needs to be known.

The software version of the unit is displayed together with the data – time information.

The software version consists of 2 numbers. The first number represent the operating software version of the unit.

6.14 Modem Connection

The unit is capable of making modem calls in case of alarm, as well as answering modem calls made from a remote location. **GSM** modems and classic cable network (**PSTN**) modems are acceptable.

If the modem is connected to the unit, the **Modem Enable** program parameter should be set to 1, otherwise faulty operation may occur. If **Modem Enable** or **SMS Enable** or **MODBUS Address** parameters are different from zero, the local PC connection will not work.

A maximum of 2 telephone numbers can be defined for outgoing modem calls. In case of alarm, the unit will attempt to reach control centers associated with each number. In case of modem connection failure, the call will be repeated up to 30 times with 2 minute intervals.



If SMS message sending is enabled, then only the first telephone number will be used for modem calls.

Advised modems are DATAKOM types which are powered up from the same DC battery voltage than the unit. Most of other desktop modems with standard AT commands are also usable, but it is the user's responsibility to provide an uninterrupted AC supply source to the modem. The necessary modem cable will be supplied by DATAKOM.

Modem calls are always terminated by the central RAINBOW software. However the unit does not allow connection durations exceeding 2 minutes, and hangs up the modem when this period expires.

The PC program used for remote monitoring and programming is the same RAINBOW software used for RS-232 connection.

Please note that the modem operation is also compatible with the MODBUS communication. Thus the unit can initiate and receive calls to/from a MODBUS master station. Please review chapter_8 for more details on MODBUS communication.

6.15 SMS Message Sending

The GSM SMS message sending is activated by setting the **SMS Enable** program parameter to 1. When the GSM SMS mode is activated, the PC connection will not work. If a local PC connection is necessary, **Modem Enable**, **SMS Enable** and **MODBUS Address** parameters should be set to 0.

When a fault condition occurs, the unit will compose an SMS message and will send it to the second and third phone numbers. Two SMS messages are sent in total.

The maximum number of alarms transmitted in a SMS message is 4. This limitation is due to the maximum length of an SMS message which is 160 characters.

A sample GSM SMS message is given below:

```
DKGxxx <SITE-ID>  
STOP :LOW OIL PRESSURE SW.  
END OF ALARM LIST
```

The first line of the message carries information about the unit type and the site identity string. This line is intended for the identification of the genset sending the SMS message.

Each following line will give one fault information. The message will always be terminated by the "END OF ALARM LIST" string.

When the message is sent, the existing alarms will be masked, causing the audible alarm relay to release and preventing consecutive GSM SMS messages. Any new upcoming alarm will result in a new GSM SMS message. The new message will indicate all existing alarms, even masked ones.

The necessary GSM modem cable will be supplied by DATAKOM. This is the same cable as PSTN (land) modems.

6.16 Remote Monitoring and Programming

Thanks to its standard serial RS-232 port, the unit offers the remote monitoring and programming feature.

The remote monitoring and programming PC software is called RAINBOW and may be downloaded from www.datakom.com.tr internet site with **password login**.

The modem, SMS and Modbus modes are not compatible with the local PC connection. **Modem Enable**, **SMS Enable** and **MODBUS Address** program parameters should be set to 0 before connection.

The RAINBOW software allows the visualization and recording of all measured parameters. The recorded parameters may then be analyzed graphically and printed. The software also allows the programming of the unit and the storage of the program parameters to PC or the downloading of stored parameters from PC to the unit.

For PCs without a serial port, below USB to serial adapters are tested and approved :

DIGITUS USB 2.0 TO RS-232 ADAPTER (PRODUCT CODE: DA70146 REV 1.1)
DIGITUS USB 1.1 TO RS-232 ADAPTER (PRODUCT CODE: DA70145 REV 1.1)
FLEXY USB 1.1 TO SERIAL ADAPTER (PRODUCT CODE BF-810)
CASECOM USB TO SERIAL CONVERTER (MODEL: RS-01)

The necessary PC connection cable will be supplied by DATAKOM.

6.17 Exerciser

The unit offers automatic exerciser operation. The exercise operation may be done on a daily, weekly or monthly basis.

The start day and time of the exercise is programmable as well as its duration. The exercise may be done with or without load following programming.

Program parameters related to the exerciser are:

Exercise start day and hour
Exercise duration
Exercise off_load/on_load
Exerciser Period (Daily / Weekly / Monthly)

Please refer to the programming section for a more detailed description of the above parameters.

When the start day and hour of exercise has come, the unit will automatically switch to either **TEST** or **LOAD TEST** mode. The engine will run and if the on_load exercise is selected then the load will be transferred to the genset.

If a mains failure occurs during the off-load exercise, the load will not be transferred to the genset unless the **Emergency Backup Operation** is allowed by setting the related program parameter to 1. Thus it is highly recommended that the Emergency Backup mode enabled with off-load exerciser.

At the end of the exercise duration, the unit will switch back to the initial mode of operation.

If any of the mode selection keys are pressed during exercise, then the exercise will be terminated.

Using the daily exercise mode, the unit may feed the load from the genset during predefined hours of the day. This operation may be used in high tariff periods of the day.

6.18. Resuming to factory set parameters

In order to resume to the factory set parameter values:

- hold pressed the **OFF**, **LAMP TEST** and **ALARM MUTE** buttons for 5 seconds,
- “**RETURN TO FACTORY SET**” will be displayed
- immediately press and hold pressed the **ALARM MUTE** button for 5 seconds
- factory set values will be reprogrammed to the parameter memory.



It is not possible to restore user parameters.

6.19. Gas Engine Fuel Solenoid Control

The unit provides a special function for the fuel solenoid control of a gas engine.

The fuel solenoid of a gas engine is different from a diesel engine. It should be opened after the cranking has been started and should be closed between crank cycles. The delay between the crank start and solenoid opening is adjusted using the **Gas Solenoid Delay** program parameter.

The gas engine fuel solenoid relay function may be assigned to spare relays using **Relay Definition** program parameters. Also relays on an extension module may be assigned to this function.

6.20. -

6.21. Load Shedding / Dummy Load

The load shedding feature consists on the disconnection of the least crucial loads when the genset power approaches to its limits. These loads will be supplied again when the genset power falls below the programmed limit. The internal Load Shedding function is always active. Any of the auxiliary relays may be used as the load shedding output.

The dummy load function consists on the connection of a dummy load if the total genset load is below a limit and to disconnection of the dummy load when the total power exceeds another limit. The dummy load function is the inverse of the load shedding function, thus the same output may be used for both purposes.

The parameters used in Load Shedding feature are in the Electrical Parameters Group:
Load Shedding Low Limit: If the genset active power output goes below this limit, then the Load Shedding relay will be deactivated.
Load Shedding High Limit: If the genset active power output goes above this limit, then the Load Shedding relay will be activated.

6.22. Firmware Update

The unit offers possibility of updating the firmware in the field. The firmware is updated through the RS-232 serial port using Rainbow or a special DOS program.

The unit will go to firmware download mode with a special command from the PC program. In download mode, the display of the unit will show "**DL-V1.00**"

During firmware update process, the progress is visible through a completion bar on the screen.

The firmware update operation will take around 3 minutes.

After completion of the update a special command will set back the unit to normal operation mode.

7. -

8. MODBUS COMMUNICATION

The unit offers the possibility of MODBUS communication via its RS232 serial port.

The connection to the MODBUS master may be done in 3 ways:

- 1) RS232 connection using directly the RS232 port provided.
- 2) RS422/485 connection using external RS422/485 converter.
- 3) Modem connection using external modem.

The MODBUS mode is activated by assigning a controller address to the unit using **MODBUS Address** program parameter. The possible address range is 1 to 144. Setting the address to 0 will **disable** the MODBUS mode and allow communication under RAINBOW protocol.

The MODBUS properties of the unit are:

- Data transfer mode: RTU
- Serial data: 9600 bps, 8 bit data, no parity, 1 bit stop
- Supported functions:
 - Function 3 (Read multiple registers)
 - Function 6 (Write single register)

Detailed description about the MODBUS protocol is found in the document "**Modicon Modbus Protocol Reference Guide**". The web address is: www.modbus.org/docs/PI_MBUS_300.pdf

Below is a limited shortlist of readable registers. For the detailed **Modbus Application Manual** and a complete list of registers please contact DATAKOM.

ADDRESS (hex)	R / W	DATA SIZE	COEFFICIENT	DESCRIPTION
0000	R	16bit	x1	Mains Phase L1 voltage
0001	R	16bit	x1	Mains Phase L2 voltage
0002	R	16bit	x1	Mains Phase L3 voltage
0003	R	16bit	x1	Genset Phase L1 voltage
0004	R	16bit	x1	Genset Phase L2 voltage
0005	R	16bit	x1	Genset Phase L3 voltage
0006	R	16bit	x1	Genset Phase L1 current
0007	R	16bit	x1	Genset Phase L2 current
0008	R	16bit	x1	Genset Phase L3 current
000C	R	16bit	x1	Mains Phase L12 voltage
000D	R	16bit	x1	Mains Phase L23 voltage
000E	R	16bit	x1	Mains Phase L31 voltage
000F	R	16bit	x1	Genset Phase L12 voltage
0010	R	16bit	x1	Genset Phase L23 voltage
0011	R	16bit	x1	Genset Phase L31 voltage
0012	R	16bit	x10	Mains frequency
0013	R	16bit	x10	Genset frequency
0016-0017	R	32bit	x256	Genset active power: this 24 bit signed register holds the genset active power multiplied by 256. Least significant 16 bits are in the register 0016h. Most significant 8 bits are in the LSB of the register 0017h.
0018	R	8bit	x100	Power factor multiplied by 100 (signed byte). Negative values indicate a capacitive power factor.
002A	R	16bit	x1	Engine speed (rpm)
002B	R	16bit	x10	Oil pressure in bars.
002C	R	16bit	x1	Coolant temperature in degrees C.
002D	R	16bit	x1	Fuel level as %
002F	R	16bit	x10	Battery voltage
003D	R	8bit	-	Operating mode bit_3: manual mode bit_4: auto mode bit_5: off mode bit_6: test mode bit_7: load test mode

9. WEEKLY OPERATION SCHEDULE

In most applications, the genset is requested to operate only in working hours. Thanks to the weekly program feature unwanted operation of the genset may be prohibited.

The unit has one programmable turn-on/turn-off time pairs for each day of week. These programmable parameters allow the genset to operate automatically only in allowed time limits.

The weekly operation schedule is **only active in AUTO** mode. In other modes it will not affect the genset operation.

In **AUTO** mode, if the operation of the genset is disabled by the weekly schedule, then **the AUTO led will flash** (instead of a steady on state).

Each turn-on/turn-off time is defined in 10 minute steps.

Unused programs should be set to 24:00.

An example setup may be as follows:

Monday	Turn_on	07:00	
Monday	Turn_off	18:00	
Tuesday	Turn_on	07:00	
Tuesday	Turn_off	18:00	
Wednesday	Turn_on	07:00	
Wednesday	Turn_off	18:00	
Thursday	Turn_on	07:00	
Thursday	Turn_off	18:00	
Friday	Turn_on	07:00	
Friday	Turn_off	18:00	
Saturday	Turn_on	07:00	
Saturday	Turn_off	13:00	
Sunday	Turn_on	24:00	(Sunday no turn on time, last operation mode continues)
Sunday	Turn_off	24:00	(Sunday no turn off time, last operation mode continues)

If the same time is used for turn on and turn off, then it will be considered as a turn-on time.

The unit has a battery backed-up precision real time clock circuit. The real time clock circuit will continue its operation even in power failures. The real time clock is precisely trimmed using the **Real Time Clock Adjust** program parameter. For more details check the programming section.

10. EVENT LOGGING

The unit keeps record of the last **100** events in order to supply information for the service personal.

The genset status information and a comprehensive set of measured values are stored within the event memory. The events are recorded with a time stamp which comes from the internal real time clock circuit of the unit.

The events are stored in a circular memory. This means that a new coming event will erase the oldest recorded event. The events are always displayed starting from the most recent one.

Events are kept in a non-volatile memory and are not affected from power failures.

Switching from one menu screen to another is made with the ◀**MENU** and **MENU**▶ buttons.

When the **EVENT RECORD** screen is displayed, each depression on the ◀**MENU** button makes the display switch to the previous event and **MENU**▶ button makes the display switch to the next event.



To exit event record pages please hold pressed ◀MENU or MENU▶ buttons.

Each event is displayed in **4** pages. Event and page numbers are shown at the top right corner of the display. Events are numbered starting from 1, number 1 being the latest one. Pages are listed from **A** to **D**. Navigation between different pages of the same event is done with ▼ and ▲ buttons.

Event sources are:

- Shutdown alarms, Load dump alarms, Warnings
- Operating mode change (OFF, AUTO, etc...)
- Periodic records.

Event record contents are:

- Event type (alarms, mode change, periodic, etc...)
- Date and time
- Genset operating mode (AUTO, MANUAL, OFF, TEST, LOAD TEST)
- Genset operation status (mains ok, running, cooldown etc...)
- Genset phase voltages L1-L2-L3
- Genset phase currents L1-L2-L3
- Genset frequency
- Genset active power (KW)
- Genset power factor
- Engine rpm
- Oil pressure
- Coolant temperature
- Fuel level
- Battery voltage
- Mains phase voltages L1-L2-L3
- Mains frequency
- Digital input statuses
- Charge input status

11. STATISTICAL COUNTERS

The unit provides a set of non resettable incremental counters for statistical purposes.

The counters consist on:

- total engine hours
- total genset KWh
- engine hours to service
- time to service
- total engine cranks
- total genset runs

These counters are kept in a non-volatile memory and are not affected from power failures.

12. MAINTENANCE



DO NOT OPEN THE UNIT
There are NO serviceable parts inside the unit.

Wipe the unit, if necessary with a soft damp cloth. Do not use chemical agents

13. PROGRAMMING

The program mode is used to program the timers, operational limits and the configuration of the unit.

To **enter the program mode**, press together **◀MENU** and **MENU▶** buttons for 1 second. The program mode is only allowed if the **PROGRAM LOCK** input is left open. If this input is tied to **GROUND**, the program value modification will be disabled to prevent unauthorized intervention. It is advised to keep the **PROGRAM LOCK** input tied to **GROUND**.

The program mode will not affect the operation of the unit. Thus programs may be modified anytime, even while the genset is running.

The program mode is driven with a two level menu system. The top menu consists on program groups and each group consists of various program parameters.

When program mode is entered, a list of available groups will be displayed. Navigation between different groups are made with ▼ and ▲ buttons. Selected group is shown in reverse video (blue on white). In order to enter inside a group, please press **MENU▶** button. In order to exit from the group to the main list please press **◀MENU** button.

Navigation inside a group is made also with ▼ and ▲ buttons. A list of available parameters will be displayed. Selected parameter is shown in reverse video (blue on white). In order display/change the value of this parameter, please press **MENU▶** button. Parameter value may be increased and decreased with ▼ and ▲ buttons. If these keys are hold pressed, the program value will be increased/decreased by steps of 10. When a program parameter is modified, it is automatically saved in memory. If **MENU▶** button is pressed, next parameter will be displayed. If **◀MENU** button is pressed, then the list of parameters in this group will be displayed.

Program parameters are kept in a non-volatile memory and are not affected from power failures.

To **exit the program mode** press one of the mode selection keys. If no button is pressed during 1 minute the program mode will be cancelled automatically.

Program Group: Controller Configuration

Parameter Definition	Unit	Factory Set	Description
LCD Contrast	-	22	This parameter is used to set LCD contrast. Adjust for the best viewing angle.
Language	-	0	<p>0: English language selected.</p> <p>1: Turkish language selected. This language may depend on the country where the unit is intended to be used.</p> <p>2: Chinese language selected</p> <p>3: The unit will ask for manual language selection at power-on.</p>
Line-to-Line Voltages	-	0	<p>0: Display Line to Neutral voltages as default</p> <p>1: Display Line to Line voltages as default</p>
Genset Default Display	-	0	<p>This parameter selects the screen which is displayed during genset on load operation.</p> <p>0: screen 3 (or 4) electrical, large characters</p> <p>1: screen 5 engine parameters, large characters</p> <p>2: screen 6 (or 7) maximum information, small characters</p> <p>3: screen 8 (or 9)</p> <p>Details of each screen are explained in chapter 3.2</p>
Fault Holdoff Timer	sec	12	This parameter defines the delay after the engine runs and before the fault monitoring is enabled.
Alarm Relay Timer	sec	60	This is the period during which the ALARM relay is active. If the period is set to 0, this will mean that the period is unlimited.
Intermittent Alarm Relay	-	0	<p>0: continuous</p> <p>1: intermittent (turns on and off every second)</p>
Charge Alternator Shutdown	-	0	<p>0: The charge input generates CHARGE FAIL warning, and does not stop the engine.</p> <p>1: The charge input generates CHARGE FAIL alarm, and stops the engine.</p>
Emergency Backup Mode	-	0	<p>0: In TEST mode, the load will not be transferred to the genset even if the mains fail.</p> <p>1: In TEST mode, the load will be transferred to the genset if the mains fail.</p>
Exercise Day and Time	-	168	<p>This parameter defines the start day and hour of the exerciser.</p> <p>Values higher or equal to 168 mean that the exerciser is off.</p> <p>The exercise may be selected to start at the beginning of the any hour of the week. The parameter value is the hour count of the start time.</p> <p>Examples:</p> <p>0 = exercise starts at Monday 00:00</p> <p>8 = exercise starts at Monday 08:00</p> <p>24 = exercise starts at Tuesday 00:00</p> <p>167 = exercise starts at Sunday 23:00</p> <p>168 = exerciser off</p> <p>If a daily exercise is selected, then the day information is don't care and the exercise will be performed every day regardless of the day selection. If the monthly exerciser is selected, then the exercise will be performed during the first 7 days of each month at the programmed day and hour.</p>

Program Group: Controller Configuration (continued)

Exercise Duration	min	10	This parameter defines the exercise duration and programmed in 10 minute steps up to 24 hours.
Exercise Off/On Load	-	0	0: Exercise at TEST mode 1: Exercise at LOAD TEST mode
Exercise Period	-	1	0: exercise every day (the exercise will be performed every day regardless of the day selection of Exercise Dat and Time parameter). 1: exercise once per week 2: exercise once per month (the exercise will be performed during the first 7 days of each month at the programmed day and hour).
Remote Start Operation	-	0	0: NORMAL MODE: the engine runs when the mains fail. 1: REMOTE START MODE: the engine runs when a signal from the SPARE-2 input comes, the unit does not monitor mains voltages.
Simulate Mains Operation	-	0	0: The SPARE-2 input has normal function 1: The SPARE-2 input simulates mains.
Delayed Simulate Mains	-	0	0: The SPARE-2 input has normal function 1: The SPARE-2 input has delayed simulate mains function. See chapter 6.8 for more info.
Modem Enable	-	0	0: No modem connection, the serial port is connected to PC 1: Modem connected.
SMS Enable	-	0	0: SMS not enabled 1: SMS enabled
GPRS Call Enable	-	0	0: standard modem calls 1: GPRS modem calls
MODBUS Address	-	0	0: RAINBOW communication protocol. 1-144: MODBUS communication. This parameter is also the MODBUS controller address of the unit.
Oil Pressure in psi	-	0	0: oil pressure display in bars 1: oil pressure display in psi
Temperature in °F	-	0	0: temperature display in degrees C 1: temperature display in degrees F
Flashing Relay Timer	hours	0	Delayed Simulate Mains Operation: max genset running time after Simulate Mains signal disappears. Dual Genset Systems: flashing relay toggle timer. Please contact DATAKOM for dual genset mutual stanby operation.
Real Time Clock Adjust	-	117	This parameter trims precisely the real time clock circuit. Values from 0 to 63 speed up the clock with 0.25sec/day steps. Values from 127 to 64 slow down the clock with 0.25sec/day steps.
Hysteresis Voltage	V	8	This parameter provides the mains and genset voltage limits with a hysteresis feature in order to prevent faulty decisions. For example, when the mains are present, the mains voltage low limit will be used as the programmed low limit. When the mains fail, the low limit will be incremented by this value. It is advised to set this value to 8 volts.

Parameter Definition	Unit	Factor y Set	Description
RPM from genset frequency	-	1	This parameter is used in the conversion of the genset frequency to engine rpm. 0: read rpm from the optional MPU input 1: convert frequency to rpm (using crank teeth count)
Crank Teeth Count	-	30	This is the number of pulses generated by the magnetic pickup sensing unit in one turn of the flywheel. This parameter is also used in the conversion of the genset frequency to engine rpm. The frequency in Hz is multiplied with this parameter during conversion to rpm.

Program Group: Electrical Parameters

Parameter Definition	Unit	Factory Set	Description
Current Transformer Ratio	A	500	This is the rated value of current transformers. All transformers must have the same rating. The secondary of the transformer will be 5 Amps.
Overcurrent Limit	A	0	If the current goes above this limit, during the period defined in Overload Timeout then a Overcurrent Load Dump alarm will be generated. If this parameter is 0 then Overcurrent check is disabled.
Excess Power Limit	KW	0	If the active power goes above this limit, during the period defined in Overload Timeout then an Excess Power Load Dump alarm will be generated. If this parameter is 0 then Excess Power check is disabled.
Overload Timeout	sec	5	This is the period between the current or active power go over the limits and OVERCURRENT or EXCESS POWER Load Dump alarms occur. This is also the period between the frequency goes out of the limits and OVERSPEED or UNDERSPEED alarms occur.
Mains Voltage Low Limit	V	170	If one of the mains phases goes under this limit, it means that the mains are off and it starts the transfer to the genset in AUTO mode.
Mains Voltage High Limit	V	270	If one of the mains phases goes over this limit, it means that the mains are off and it starts the transfer to the genset in AUTO mode.
Genset Voltage Low Limit	V	170	If one of the generator phase voltages goes under this limit when feeding the load, this will generate a GENSET LOW VOLTAGE alarm and the engine will stop.
Genset Voltage High Limit	V	270	If one of the generator phase voltages goes over this limit when feeding the load, this will generate a GENSET HIGH VOLTAGE alarm and the engine will stop.

Parameter Definition	Unit	Factory Set	Description
Low Battery Voltage Warning	V	9.0	If the battery voltage falls below this limit, this will generate a LOW BATTERY warning.
High Battery Voltage Warning	V	31.0	If the battery voltage goes over this limit, this will generate a HIGH BATTERY warning.
High Battery Voltage Shutdown	V	33.0	If the battery voltage goes over this limit, this will generate a HIGH BATTERY shutdown alarm and the engine will stop.
Mains Waiting Timer	min	0.5	This is the time between the mains voltages entered within the limits and the generator contactor is deactivated.
Genset Contactor Timer	sec	1	This is the period after the mains contactor has been deactivated and before the generator contactor has been activated.
Mains Contactor Timer	sec	1	This is the period after the generator contactor has been deactivated and before the mains contactor has been activated.
Mains Phase Order Enable	-	0	0: mains phase order checking disabled 1: if mains phase order is faulty, then a warning is given and mains contactor deenergized.
Load Shedding Low Limit	KW	0	If the genset power goes below this limit then the load shedding relay will be deactivated.
Load Shedding High Limit	KW	0	If the genset power goes above this limit then the load shedding relay will be activated.

Program Group: Engine Parameters

Parameter Definition	Unit	Factory Set	Description
Low Frequency Shutdown	Hz	30	If the genset frequency goes under this limit, a GENSET LOW FREQUENCY alarm is generated and the engine stops.
Low Frequency Warning	Hz	35	If the genset frequency goes under this limit, a GENSET LOW FREQUENCY warning is generated.
High Frequency Warning	Hz	54	If the genset frequency goes over this limit, a GENSET HIGH FREQUENCY warning is generated.
High Frequency Shutdown	Hz	55	If the genset frequency goes over this limit, a GENSET HIGH FREQUENCY alarm is generated and the engine stops.
Low Oil Pressure Warning	bar	1.4	If the oil pressure measured from the analog input falls below this limit, this will generate a LOW OIL PRESSURE SENDER warning.
Low Oil Pressure Shutdown	bar	1.0	If the oil pressure measured from the analog input falls below this limit, this will generate a LOW OIL PRESSURE SENDER alarm is generated and the engine stops.
High Temperature Warning	°C	95	If the coolant temperature measured from the analog input goes over this limit, this will generate a HIGH TEMPERATURE SENDER warning.
High Temperature Shutdown	°C	98	If the coolant temperature measured from the analog input goes over this limit, this will generate a HIGH TEMPERATURE SENDER alarm and the engine will stop.
Oil Pressure Sender type	-	1	This parameter selects the oil pressure sender type. 0: Non standard sender. The sender characteristics are defined in Sender Characteristics table. 1: VDO 0-7 bars (10-180 ohms) 2: VDO 0-10 bars (10-180 ohms) 3: DATCON 0-7 bars (240-33 ohms) 4: DATCON 0-10 bars (240-33 ohms) 5: DATCON 0-7 bars (0-90 ohms) 6: DATCON 0-10 bars (0-90 ohms) 7: DATCON 0-7 bars (75-10 ohms)
Coolant Temp. Sender Type	-	1	This parameter selects the temperature sender type: 0: The sender characteristics are defined in Sender Characteristics table. 1: VDO 2: DATCON DAH type 3: DATCON DAL type
Engine Heating Temperature	°C	50	If it is requested that the engine runs without load until reaching a certain temperature, this parameter defines the temperature.
Engine Start Delay	sec	0	This is the time between the mains fails and the fuel solenoid turns on before starting the genset. It prevents unwanted genset operation in battery backed-up loads.
Preheat Timer	sec	1	This is the time after the fuel solenoid is energized and before the genset is started. During this period the PREHEAT relay output is energized (if assigned by Relay Definitions)

Program Group: Engine Parameters (continued)

Parameter Definition	Unit	Factory Set	Description
Crank Timer	sec	10	This is the maximum start period. Starting will be automatically cancelled if the genset fires before the timer.
Wait Between Starts	sec	10	This is the waiting period between two start attempts.
Engine Heating Timer	sec	4	This is the period used for engine heating following the program parameter.
Cooldown Timer	min	1.0	This is the period that the generator runs for cooling purpose after the load is transferred to mains.
Stop Solenoid Timer	sec	10	This is the maximum time duration for the engine to stop. During this period the STOP relay output is energized (if assigned by Relay Definitions). If the genset has not stopped after this period, a FAIL TO STOP warning occurs.
Number of Starts	-	3	This is the maximum number of start attempts.
Engine Heating Method	-	0	This parameter defines the engine heating method. The genset will not take the load before engine heating is completed. 0: engine is heated during Engine Heating Timer . 1: engine is heated until the coolant temperature reaches the Engine Heating Temperature and at least during the Engine Heating Timer .
Service Engine Hours	hour	50	The SERVICE REQUEST led indicator will turn on after this quantity of engine hours from the last service. If the period is set to '0' no SERVICE REQUEST will be generated depending on engine hours.
Service Period	month	6	The SERVICE REQUEST led indicator will turn on after this amount of time from the last service. If the period is set to '0' no SERVICE REQUEST will be indicated depending on time.
Idle Speed Timer	sec	0	When the engine runs, the Idle output relay function will be active during this timer.
Gas Solenoid Delay	sec	5	The gas solenoid of the gas engine will be opened after this delay during cranking.
Low Fuel Warning	%	20	If the fuel level measured from the analog input falls below this limit, a LOW FUEL LEVEL SENDER warning is generated.
Low Fuel Shutdown	%	10	the fuel level measured from the analog input falls below this limit, a LOW FUEL LEVEL SENDER shutdown alarm is generated and the engine stops.
Fuel Level sender Ohms	ohms	180	Fuel level sender max resistance. 180 ohms and 300 ohms senders are common.

Program Group: Adjust Date and Time

Parameter Definition	Unit	Factory Set	Description
Date	-	01-31	Current day of the month.
Month	-	01-12	Current month.
Year	-	00-99	Last two digits of the current year.
Hours	-	00-23	Current hour of the day.
Minutes	-	00-59	Current minute of the hour.
Seconds	-	00-59	Current second of the minute.

Program Group: Weekly Schedule

Parameter Definition	Unit	Factory Set	Description
Monday Turn_on	-	24:00	Please review chapter 9 for a detailed description of weekly programming schedule operation.
Monday Turn_off	-	24:00	
Tuesday Turn_on	-	24:00	
Tuesday Turn_off	-	24:00	
Wednesday Turn_on	-	24:00	
Wednesday Turn_off	-	24:00	
Thursday Turn_on	-	24:00	
Thursday Turn_off	-	24:00	
Friday Turn_on	-	24:00	
Friday Turn_off	-	24:00	
Saturday Turn_on	-	24:00	
Saturday Turn_off	-	24:00	
Sunday Turn_on	-	24:00	
Sunday Turn_off	-	24:00	

Program Group: Sender Characteristics

Parameter Definition	Unit	Factory Set	Description
Oil Pressure Sender Ohms - 1	ohm	10	Oil Pressure Sender point 1, ohm value
Oil Pressure Value -1	bar	0.0	Oil Pressure Sender point 1, bar value
Oil Pressure Sender Ohms - 2	ohm	52	Oil Pressure Sender point 2, ohm value
Oil Pressure Value -2	bar	2.0	Oil Pressure Sender point 2, bar value
Oil Pressure Sender Ohms - 3	ohm	90	Oil Pressure Sender point 3, ohm value
Oil Pressure Value -3	bar	4.0	Oil Pressure Sender point 3, bar value
Oil Pressure Sender Ohms - 4	ohm	140	Oil Pressure Sender point 4, ohm value
Oil Pressure Value -4	bar	7.0	Oil Pressure Sender point 4, bar value
Oil Pressure Sender Ohms - 5	ohm	156	Oil Pressure Sender point 5, ohm value
Oil Pressure Value -5	bar	8.0	Oil Pressure Sender point 5, bar value
Oil Pressure Sender Ohms - 6	ohm	184	Oil Pressure Sender point 6, ohm value
Oil Pressure Value -6	bar	10.0	Oil Pressure Sender point 6, bar value

Program Group: Sender Characteristics (continued)

Parameter Definition	Unit	Factory Set	Description
Temperature Sender Ohms - 1	ohm	38	Temperature Sender point 1, ohm value
Temperature Value -1	°C	100	Temperature Sender point 1, °C value
Temperature Sender Ohms - 2	ohm	51	Temperature Sender point 2, ohm value
Temperature Value -2	°C	90	Temperature Sender point 2, °C value
Temperature Sender Ohms - 3	ohm	134	Temperature Sender point 3, ohm value
Temperature Value -3	°C	60	Temperature Sender point 3, °C value
Temperature Sender Ohms - 4	ohm	322	Temperature Sender point 4, ohm value
Temperature Value -4	°C	39	Temperature Sender point 4, °C value
Temperature Sender Ohms - 5	ohm	650	Temperature Sender point 5, ohm value
Temperature Value -5	°C	20	Temperature Sender point 5, °C value
Temperature Sender Ohms - 6	ohm	1630	Temperature Sender point 6, ohm value
Temperature Value -6	°C	02	Temperature Sender point 6, °C value

Program Group: Input Configuration (Low Oil Pressure Switch)

Parameter Definition	Unit	Factory Set	Description
Action		0	0: Shutdown (the engine stops immediately) 1: Load Dump (the engine stops after cooldown) 2: Warning (the horn relay operates) 3: No operation
Sampling		1	0: Always 1: After holdoff timer 2: When mains present
Latching		1	0: Non latching 1: Latching
Contact type		0	0: Normally open 1: Normally closed
Switching		0	0: Battery negative 1: Battery positive
Response delay		0	0: No delay 1: Delayed (4sec)

Program Group: Input Configuration (High Temperature Switch)

Parameter Definition	Unit	Factory Set	Description
Action		0	0: Shutdown (the engine stops immediately) 1: Load Dump (the engine stops after cooldown) 2: Warning (the horn relay operates) 3: No operation
Sampling		1	0: Always 1: After holdoff timer 2: When mains present
Latching		1	0: Non latching 1: Latching
Contact type		0	0: Normally open 1: Normally closed
Switching		0	0: Battery negative 1: Battery positive
Response delay		0	0: No delay 1: Delayed (4sec)

Program Group: Input Configuration (Coolant Level Switch)

Parameter Definition	Unit	Fac.Set	Description
Action		0	0: Shutdown (the engine stops immediately) 1: Load Dump (the engine stops after cooldown) 2: Warning (the horn relay operates) 3: No operation
Sampling		0	0: Always 1: After holdoff timer 2: When mains present
Latching		1	0: Non latching 1: Latching
Contact type		0	0: Normally open 1: Normally closed
Switching		0	0: Battery negative 1: Battery positive
Response delay		1	0: No delay 1: Delayed (4sec)

Program Group: Input Configuration (Rectifier Fail)

Parameter Definition	Unit	Fac.Set	Description
Action		2	0: Shutdown (the engine stops immediately) 1: Load Dump (the engine stops after cooldown) 2: Warning (the horn relay operates) 3: No operation
Sampling		2	0: Always 1: After holdoff timer 2: When mains present
Latching		1	0: Non latching 1: Latching
Contact type		0	0: Normally open 1: Normally closed
Switching		0	0: Battery negative 1: Battery positive
Response delay		0	0: No delay 1: Delayed (4sec)

Program Group: Input Configuration (Emergency Stop)

Parameter Definition	Unit	Fac.Set	Description
Action		0	0: Shutdown (the engine stops immediately) 1: Load Dump (the engine stops after cooldown) 2: Warning (the horn relay operates) 3: No operation
Sampling		0	0: Always 1: After holdoff timer 2: When mains present
Latching		0	0: Non latching 1: Latching
Contact type		0	0: Normally open 1: Normally closed
Switching		0	0: Battery negative 1: Battery positive
Response delay		0	0: No delay 1: Delayed (4sec)

Program Group: Input Configuration (Spare-1 Input)

Parameter Definition	Unit	Fac.Set	Description
Action		2	0: Shutdown (the engine stops immediately) 1: Load Dump (the engine stops after cooldown) 2: Warning (the horn relay operates) 3: No operation
Sampling		0	0: Always 1: After holdoff timer 2: When mains present
Latching		0	0: Non latching 1: Latching
Contact type		0	0: Normally open 1: Normally closed
Switching		0	0: Battery negative 1: Battery positive
Response delay		0	0: No delay 1: Delayed (4sec)

Program Group: Input Configuration (Spare-2 Input)

Parameter Definition	Unit	Fac.Set	Description
Action		2	0: Shutdown (the engine stops immediately) 1: Load Dump (the engine stops after cooldown) 2: Warning (the horn relay operates) 3: No operation
Sampling		0	0: Always 1: After holdoff timer 2: When mains present
Latching		0	0: Non latching 1: Latching
Contact type		0	0: Normally open 1: Normally closed
Switching		0	0: Battery negative 1: Battery positive
Response delay		0	0: No delay 1: Delayed (4sec)

Program Group: Input Configuration (Low Fuel Switch Input)

Parameter Definition	Unit	Fac.Set	Description
Action		0	0: Shutdown (the engine stops immediately) 1: Load Dump (the engine stops after cooldown) 2: Warning (the horn relay operates) 3: No operation
Sampling		0	0: Always 1: After holdoff timer 2: When mains present
Latching		1	0: Non latching 1: Latching
Contact type		0	0: Normally open 1: Normally closed
Switching		0	0: Battery negative 1: Battery positive
Response delay		0	0: No delay 1: Delayed (4sec)

Program Group: Relay Definitions

The parameters below define the functions of relay outputs. The unit has 6 relay outputs. The fixed function relays are Fuel, Start, Mains Contactor and Generator Contactor. RELAY-1 and RELAY-2 have programmable functions, selected from a list.

The relays may be extended up to 22 using **Relay Extension Modules**. Other relays are in the optional Extension Modules.

Parameter Definition	Unit	Fac.Set	Description
Relay 01 Definition		3	RELAY-1 function selected from list (terminal 29)
Relay 02 Definition		1	RELAY-2 function selected from list (terminal 28)
Relay 03 Definition		0	RELAY-3 function (expansion module) selected from list
Relay 04 Definition		2	RELAY-4 function (expansion module-1) selected from list
Relay 05 Definition		4	RELAY-5 function (expansion module-1) selected from list
Relay 06 Definition		5	RELAY-6 function (expansion module-1) selected from list
Relay 07 Definition		0	RELAY-7 function (expansion module-1) selected from list
Relay 08 Definition		2	RELAY-8 function (expansion module-1) selected from list
Relay 09 Definition		4	RELAY-9 function (expansion module-1) selected from list
Relay 10 Definition		5	RELAY-10 function (expansion module-1) selected from list
Relay 11 Definition		0	RELAY-11 function (expansion module-2) selected from list
Relay 12 Definition		2	RELAY-12 function (expansion module-2) selected from list
Relay 13 Definition		4	RELAY-13 function (expansion module-2) selected from list
Relay 14 Definition		5	RELAY-14 function (expansion module-2) selected from list
Relay 15 Definition		0	RELAY-15 function (expansion module-2) selected from list
Relay 16 Definition		2	RELAY-16 function (expansion module-2) selected from list
Relay 17 Definition		4	RELAY-17 function (expansion module-2) selected from list
Relay 18 Definition		5	RELAY-18 function (expansion module-2) selected from list

The function of a programmable relay output may be selected from the below list.

00	Fuel
01	Alarm
02	Start
03	Stop
04	Gen. Contactor
05	Mains Contactor
06	Choke
07	Preheat
08	Shutdown alarm
09	Shutdown or load_dump alarm
10	Shutdown or load_dump or warning
11	Automatic ready
12	Week. on time
13	Exerciser on
14	Load_dump alarm
15	-
16	Mains Fail
17	Block Heater
18	Service Request
19	-
20	Load Shedding Relay
21	Flashing Relay
22	Gas Solenoid
23	Fuel Pump
24	Mains Phase Order Fail
25	Genset Phase Order Fail
26	Idle Speed
27	-
28	-
29	-
30	-
31	-

32	Oil switch alarm
33	Temp switch alarm
34	Coolant Level switch alarm
35	Rectifier alarm
36	Emerg.Stop alarm
37	Spare-1 Alarm
38	Spare-2 Alarm
39	Fuel Level switch alarm
40	Oil sender alarm
41	Temp sender alarm
42	Low speed alarm
43	High speed alarm
44	Low voltage alarm
45	High voltagealarm
46	Fail to start alarm
47	Low fuel sender alarm
48	-
49	-
50	-
51	High battery voltage alarm
52	Charge fail alarm
53	-
54	-
55	-
56	Oil switch load_dump
57	Temp switch load_dump
58	Coolant Level switch load_dump
59	Rectifier load_dump
60	Emerg.Stop load_dump
61	Spare-1 load_dump
62	Spare-2 load_dump
63	Fuel Level switch load_dump
64	-
65	-
66	-
67	-
68	-
69	-
70	-
71	-
72	Overcurrent load_dump
73	Excess power load_dump
74	-
75	-
76	-
77	-
78	-
79	-

80	Oil switch warning
81	Temp switch warn.
82	Coolant Level switch warning
83	Rectifier warning
84	Emerg Stop warn.
85	Spare-1 warning
86	Spare-2 warning
87	Fuel Level switch warning
88	Oil sender warning
89	Temp sender warn.
90	Low speed warning
91	High speed warning
92	-
93	-
94	Fail to stop warning
95	Low fuel sender warning
96	Service request warning
97	Mains Phase Order Fail
98	Low battery warning
99	High battery warning
100	Charge fail warning
101	-
102	-
103	-

Program Group: Site Id

Parameter Definition	Factory Set	Description
Site Id String	DATAKOM SITE ID	This is the site Id string sent at the beginning of an SMS message for the identification of the genset sending the SMS message. Any 20 character long string may be entered.

Program Group: Modem-1 Telephone Number

Parameter Definition	Factory Set	Description
Modem-1 telephone number	-----	This is the telephone number used for modem calls. The buffer accepts up to 16 digits, including the wait charater (“;”) in order to enable dialing through a pabx.

Program Group: Modem-2 / SMS-1 Telephone Number

Parameter Definition	Factory Set	Description
Modem-2 / SMS-1 telephone number	-----	This telephone number buffer accepts up to 16 digits, including the wait charater (“;”) in order to enable dialing through a pabx. If Modem Enabled: This is the second telephone number used for modem calls. If Modem Disabled: This is the first SMS telephone number.

Program Group: SMS-2 Telephone Number

Parameter Definition	Factory Set	Description
SMS-2 telephone number	-----	This telephone number buffer accepts up to 16 digits, including the wait charater (“;”) in order to enable dialing through a pabx. This is the first or second SMS telephone number following Modem Enable parameter.

Program Group: Calibration Parameters

These parameters adjust measurement calibration of the unit. Manual calibration is also allowed. During calibration, measurements to be calibrated are also visualized.

Parameter Definition	Unit	Fac.Set	Description
Mains Voltage L1 Calibration	-	760	Adjusts the measurement of mains voltage of phase L1
Mains Voltage L2 Calibration	-	760	Adjusts the measurement of mains voltage of phase L2
Mains Voltage L3 Calibration	-	760	Adjusts the measurement of mains voltage of phase L3
Genset Voltage L1 Calibration	-	760	Adjusts the measurement of genset voltage of phase L1
Genset Voltage L2 Calibration	-	760	Adjusts the measurement of genset voltage of phase L2
Genset Voltage L3 Calibration	-	760	Adjusts the measurement of genset voltage of phase L3
Genset Current L1 Calibration	-	6360	Adjusts the measurement of genset current of phase L1
Genset Current L2 Calibration	-	6360	Adjusts the measurement of genset current of phase L2
Genset Current L3 Calibration	-	6360	Adjusts the measurement of genset current of phase L3
Active power calibration		14800	Total active power measurement calibration.
Power factor calibration		172	Power factor measurement calibration.
Battery voltage calibration		139	Battery voltage measurement calibration.

14. TROUBLESHOOTING

The genset operates while AC mains are OK or continues to operate after AC mains are OK:

- Check engine body grounding.
- AC mains voltages may be outside programmed limits, measure the phase voltages.
- Check the AC voltage readings by pressing the MENU button.
- Upper and lower limits of the mains voltages may be too tight. Check the parameters **Mains Voltage Low Limit** and **Mains Voltage High Limit**. Standard values are 170/270 volts.
- The hysteresis voltage may be given to excessive. The standard value is 8 volts.

AC voltages or frequency displayed on the unit are not correct:

- Check engine body grounding, it is necessary.
- The error margin of the unit is +/- 3 volts.
- If there are faulty measurements only when the engine is running, there may be a faulty charging alternator or voltage regulator on the engine. Disconnect the charging alternator connection of the engine and check if the error is removed.
- If there are faulty measurements only when mains are present, then the battery charger may be failed. Turn off the rectifier fuse and check again.

Phase-to-Phase AC voltages are not correct although Phase to Neutral voltages are correct:

- Incorrect phase order. Please connect phase voltages in the correct order.

KW and cos Φ readings are faulty although the Amp readings are correct:

- Current transformers are not connected to the correct inputs or some of the CTs are connected with reverse polarity. Determine the correct connections of each individual CT in order to obtain correct KW and cos Φ for the related phase, and then connect all CTs.



Short circuit the outputs of unused Current Transformers.

When the AC mains fails the unit energizes the fuel solenoid, but does not start and OIL PRESSURE EXISTS ! message is displayed:

- The unit is not supplied with battery (-) voltage at the oil pressure input.
- Oil pressure switch not connected.
 - Oil pressure switch connection wire cut.
 - Oil pressure switch faulty.
 - Oil pressure switch closes too lately. If oil pressure switch closes, the unit will start. Optionally oil pressure switch may be replaced.

The engine does not run after the first start attempt, then the unit does not start again and OIL PRESSURE EXISTS ! message is displayed:

- The oil pressure switch closes very lately. As the unit senses an oil pressure, it does not start. When oil pressure switch closes the unit will start. Optionally the oil pressure switch may be replaced.

When the AC mains fails, the engine starts to run but the unit gives START FAIL alarm and then the engine stops:

-The generator phase voltages are not connected to the unit. Measure the AC voltage between terminals **GEN L1-L2-L3** and **Generator Neutral** at the rear of the unit while the engine is running. A fuse protecting the generator phases may be failed. A misconnection may be occurred. If everything is OK, turn all the fuses off, and then turn all the fuses on, starting from the DC supply fuse. Then test the unit again.

The unit is late to remove engine cranking:

-The generator voltage rises lately. Also the generator remnant voltage is below 20 volts. The unit removes starting with the generator frequency, and needs at least 20 volts to measure the frequency. If this situation is to be avoided, the only solution is to add an auxiliary relay. The coil of the relay will be between BATTERY (-) and charging alternator D+ terminal. The normally closed contact of the relay will be connected serially to the unit's START output. So the starting will also be removed when the D+ pulls to battery positive.

The unit is inoperative:

Measure the DC-supply voltage between terminals 19 and 22 at the rear of the unit. If OK, turn all the fuses off, then turn all the fuses on, starting from the DC supply fuse. Then test the unit again.

Programming mode can not be entered:

The program lock input disables programming mode entry. Disconnect the program lock input from battery negative before modification. Do not forget to make this connection again to prevent unauthorized program modifications.

Some program parameters are skipped:

These parameters are reserved for factory setting and cannot be modified.

AUTO led flashes and the genset does not run when mains fail:

The unit is in Weekly Schedule **OFF** time. Please check date and time setting of the unit. Please check also Weekly Schedule program parameters.

15. DECLARATION OF CONFORMITY

The unit conforms to the EU directives

-2006/95/EC (low voltage)

-2004/108/EC (electro-magnetic compatibility)

Norms of reference:

EN 61010 (safety requirements)

EN 61326 (EMC requirements)

The CE mark indicates that this product complies with the European requirements for safety, health environmental and customer protection.

16. TECHNICAL SPECIFICATIONS

Alternator voltage: 0 to 300 V-AC Phase to Neutral (0 to 520 V-AC Phase to Phase)

Alternator frequency: 0-100 Hz.

Mains voltage: 0 to 300 V-AC Phase to Neutral (0 to 520 V-AC Phase to Phase)

Mains frequency: 0-100 Hz.

DC Supply range: 9.0 VDC to 30.0 VDC

Cranking dropouts: survives 0 V for 100ms

Typical stand-by current consumption: 130 mADC.

Maximum current consumption: 250 mADC.

Generator/mains contactor outputs: 16 A @ 250 VAC.

DC outputs: 1A @ 28 VDC. Protected semiconductor outputs.

Charge alternator excitation current: min 150 mADC @ 10 to 30 VDC.

Current inputs: from current transformers, .../5A. Max load 0.7VA per phase.

Digital inputs: input voltage 0 - 30 VDC. Internally connected to battery positive via 4700 ohm resistor.

Analog inputs: Resistor input 0 to 5000 ohms connected to the battery negative. Sources 10 mA when closed to battery negative.

Measurement category: CAT II

Air category: Pollution degree II

Communication port: RS-232. 9600 bauds, no parity, 1 stop bit.

Operating temperature range: -20°C to +70°C (-4 °F to +158 °F)

Storage temperature range: -40°C to +80°C (-40 °F to +176 °F)

Maximum humidity: 95%, non-condensing

Dimensions: 165x125x48mm (WxHxD)

Panel Cut-out dimensions: 151 x 111mm minimum.

Weight: 350 g (approx.)

Case material: High temperature, self extinguishing ABS/PC (UL94-V0)

IP protection: IP65 from front panel, IP30 from the rear

15. CONNECTION DIAGRAM

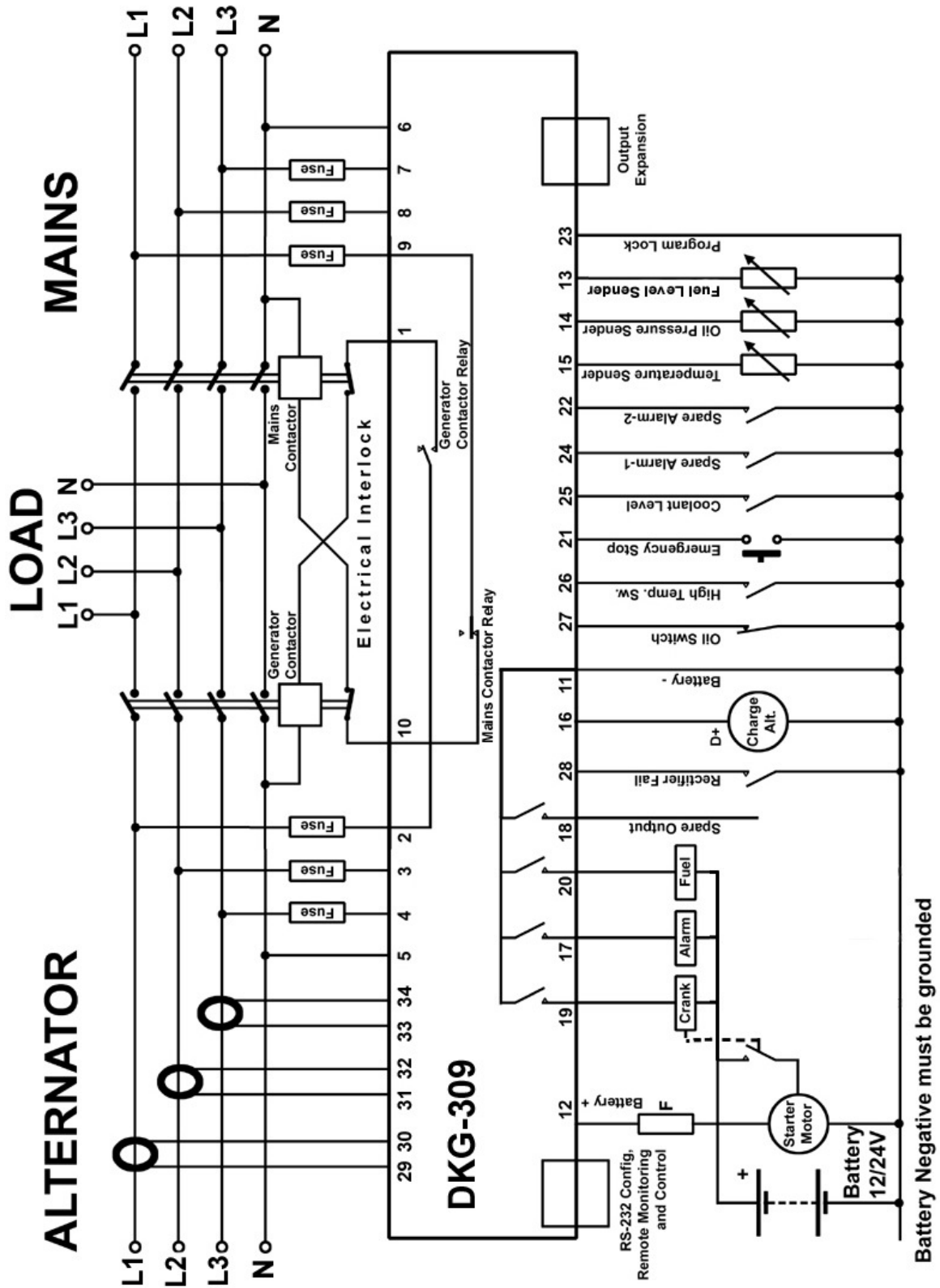

ERROR: stackunderflow
OFFENDING COMMAND: ~

STACK: