

## WT-SC330 300KVA Technical Data sheet



# DIESEL GENERATOR

**WINTPOWER®**

Gensets model	Prime Power (50hz)	Standby Power (50hz)	Engine Model	Alternator Model
<b>WT-SC330</b>	<b>300KVA/240KW</b>	<b>330KVA/264KW</b>	<b>SC12E420D2</b>	<b>WT444ES</b>

## General Features:

ΔSDEC diesel engine made by SDEC China, with radiator at ambient temperature 40°C, fans are driven by belt, with safety guard

ΔWintpower Alternator with single bearing alternator; IF Protection, Insulation class H

ΔAir Filter, Oil filter and fuel filter fitted

ΔLube-oil drain valve fitted

ΔElectric Starter Charge motor 24 VD.C

Δ Battery Charger

ΔOptional soundproof and weatherproof canopy

Δ3 pole MCCB Delixi breaker/Optional ABB

ΔOperation & Maintenance manual

ΔAccessory: A suit of ripple flex exhaust pipe; exhaust siphon, muffler; and a set of spare parts & Tools

Δ The structure is built-up, the built-in residential muffler makes the noise lower.

ΔExhaust guide plate and air channel for air intake&noise reduction are mounted within soundproof canopies.

ΔOutside Emergency Stop Button.

Δ 8 Hours Base Fuel tank is equipped, With lifting ear and forklift slots. Outside fuel inlet/return, outside lub oil and coolant drain.

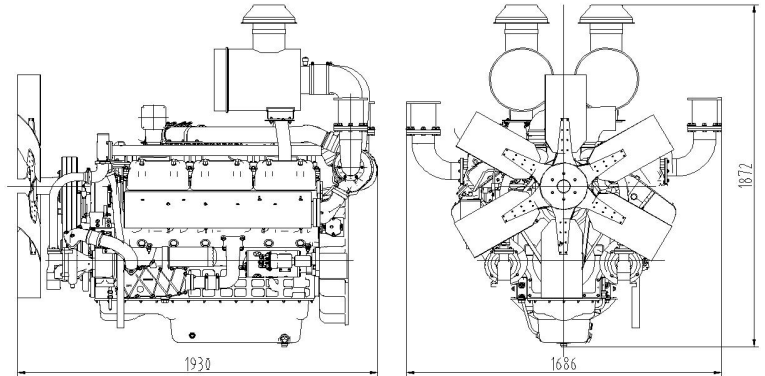

## Voltage Regulation:

Voltage regulation maintained within  $\pm 0.5\%$

Between 0.8 and 1.0 lagging and unity

From no load to full load

At speed droop variation upto 4.5%

## Frequency Adjustable Ratio:

Change load from 0-100%, within 1.0% (electric speed regulator), within 4.5% (mechanical speed regulator)

## Frequency Undulation:

load from 0-100%, frequency undulation within 0.25%

No load wire volts max undulation ration\ within 1.8%

Three Phrase balanced load in the order of 5%

## Note:

1)The engine performance is as per GB/T2820/Ratings are based on GB/T1147.1.

2)Prime Power (PRP): Prime power is available for continuous 12-hours running, in accordance with GB/T2820, ISO8528; A 10% overload capability is available for a period of 1 hour within a 12-hours period of operation. Standby Power Rating (ESP): The standby power rating is applicable for supplying emergency power. No overload, soundproof gensets only run under rating power.

3) Standby power is available in the event of a utility power outage or under test conditions for up to 200 hours of operation per year. The permissible average power output over 24 hours of operation shall not exceed 80% of the standby power rating.

## Sales Promise:

(1) All the gensets are tested on load before they leave factory, various kinds of functions are tested . and test reports are provided.

(2) Warranty for all of our gensets and accessories is according to our standard conditions since testing: 24 months or 1500 running hours accumutively, subject to the earlier, kindly refer to our service terms.

## Engine Technical Data Sheet

◎ SPECIFICATIONS		◎ FUEL CONSUMPTION	
○ Engine Model	SC13G420D2	○ Power	lit/hr
○ Engine Type	In-line,4 strokes, water-cooled Turbo charged Air-to-air intercooled	25%	15.8
○ Combustion type	Direct injection	50%	31.6
○ Cylinder Type	Wet liner	75%	47.1
○ Number of cylinders	6	100%	65.2
○ Bore × stroke	135(5.32) ×150(5.9) mm(in.)	110%	72.8
○ Displacement	12,88(786) lit.(in3)	◎ FUEL SYSTEM	
○ Compression ratio	15.55: 1	○ Injection pump	Yijie in-line "P" type
○ Firing order	1-5-3-6-2-4	○ Governor	Electric type
○ Injection timing	14.5°BTDC	○ Feed pump	Mechanical type
○ Dry weight	Approx.1296kg (2857.2 lb)	○ Injection nozzle	Multi hole type
○ Dimension	1704×1063×1540 mm	○ Opening pressure	240kg/cm2 (3414 psi)
○ (L×W×H)	(67.1×41.9×60.7 in.)	○ Fuel filter	Full flow, cartridge type
○ Rotation	Counter clockwise viewed from Flywheel	○ Used fuel	Diesel fuel oil
○ Fly wheel housing	SAE NO.1		
○ Fly wheel	SAE NO.14		
◎ MECHANISM		◎ LUBRICATION SYSTEM	
○ Type	Over head valve	○ Lub. Method	Fully forced pressure feed type
○ Number of valve	Intake 1, exhaust 1 per cylinder	○ Oil pump	Gear type driven by crankshaft
○ Valve lashes at cold	Intake 0.325mm (0.0128 in.)	○ Oil filter	Full flow, cartridge type
○ Valve lashes at cold	Exhaust 0.375mm (0.0148 in.)	○ Oil pan capacity	High level 41 liters ( 10.82 gal.)
		○ Oil pan capacity	Low level 33 liters ( 8.71 gal.)
◎ VALVE TIMING		○ Angularity limit	Front down 25 deg.
	Opening	Close	
○ Intake valve	20 deg. BTDC	48 deg. ABDC	○ Angularity limit
○ Exhaust valve	48 deg. BBDC	20 deg. ATDC	Front up 35 deg.
			○ Angularity limit
			Side to side 35 deg.
◎ COOLING SYSTEM		◎ ENGINEERING DATA	
○ Cooling method	Fresh water forced circulation	○ Water flow	450 liters/min @1,500 rpm
○ Water capacity (engine only)	25.5 liters ( 6.73 gal.)	○ Heat rejection to coolant	32.5 kcal/sec @1,500 rpm

o Pressure system	Max. 0.5 kg/cm <sup>2</sup> ( 7.11 psi)	o Air flow	17.8 m <sup>3</sup> /min @1,500 rpm
o Water pump	Centrifugal type driven by belt	o Exhaust gas flow	44.2 m <sup>3</sup> /min @1,500 rpm
o Water pump Capacity	450 liters ( 118.8 gal.)/min	o Exhaust gas temp. restrictions	600 °C @1,500 rpm
o Thermostat	Wax–pellet type	o Intake system	3 kPa initial
o Thermostat	Opening temp. 77°C	o Intake system	6 kPa final
o Thermostat	Full open temp. 90°C	o Exhaust system	6 kPa max.
o Cooling fan	Blower type,iron 920 mm diameter, 6 blades	o Max. permissible altitude	2,000 m
o Cooling air flow	8.83m <sup>3</sup> /s		

### © ELECTRICAL SYSTEM

o Charging generator	28V×55A	in. = mm × 0.0394	lb/ft = N.m × 0.737
o Voltage regulator	Built-in type IC regulator	PS = kW × 1.3596	U.S. gal = lit. × 0.264
o Starting motor	24V×7.5kW	psi = kg/cm <sup>2</sup> × 14.2233	kW = 0.2388 kcal/s
o Battery Voltage	24V	in <sup>3</sup> = lit. × 61.02	lb/PS.h = g/kW.h × 0.00162
o Battery Capacity	180 AH	in. = mm × 0.0394	lb/ft = N.m × 0.737
		hp = PS × 0.98635	cfm = m <sup>3</sup> /min × 35.336
		lb = kg × 2.20462	

### © CONVERSION TABLE

## Alternator Technical data

### WINTPOWER WT444ES

Δ Brushless,self exciting	Exciter	Brushless
Δ class "H" insulation	Cooling Fan	Cast alloy aluminum
Δ Standard degree of protection is IP23	Bearing	Single,double shielded
Δ self regulating	Windings	100% copper
Δ With fan cooling	Connection Type	Reconnectable
Δ Resist Humid grease	Insulation Type	Class H
Δ AC excitation,roating rectification tube	Pitch	2/3
Δ Stator grease insulation covered	Amortisseur Winding	Full
Δ Rotator and exciation high polymer,Resist the corruption of oil and acid	Voltage Regulator	AVR SX460
	Voltage Regulator NL-FL	±0.5%
Δ Rotator ballance is in accordance with BS5625 standard 12.5	Underspeed Protection	Standard
	Overexcitation Protection	IP23
Δ High-quality lubrication sealed long-time bearing	TIF (1960 Weightings)	<50
Δ Rotator silicon steel close tight	Exciation System	SHUNT

## Control Panel - DEEPSEA DSE7320

The base mounted control panel in a vibration isolated sheet steel enclosure.The control panel is equipped as

a) Instruments:Analogue Volmeter,Hours Run Meter.Water pressure Meter.

b) Controls:Emergency Stop Pushbutton,Volmeter Phase Selector Switch.

c) Control module:Standard collocation is DEEPSEA DSE7320

### Main Features:

- Δ Automatic or manual start/stop of the genset
- Δ 3 phase AMF function
- Δ configuration analog inputs
- Δ Configurable programmable binary inputs and outputs



DEEPSEA DSE7320 CONTROLLER

- Δ Warm-up and cooling functions
- Δ Battery voltage, engine speed measurement
- Δ Modem communication support(IL-AMF25 only)
- Δ RS232 interface
- Δ Support of engines equipped with Electronic Control Unit (J1939 interface)
- Δ Graphic back-lit LCD display
- Δ Comprehensive diagnostic messages; SPN/FMI codes;KWP2000 Support
- Δ 6 LED indicators
- Δ Sealed to IP65
- Δ Generator C.B and Mains C.B control with feedback and return timer

### Optional SYK1 (SuYang) Automatic Transfer Switch Without/With Cabinet

The Automatic Transfer Switch Without/With Cabinet Main Function as follows:

ATS can automatically transfer load between the main power and the emergency power(generating set) without operator. When the main power fails or voltage drops below 80% of normal voltage, the ATS will start emergency generating set after a preset time 0-10 seconds(adjustable), and transfer the load to emergency power(generating set). Contrarily, when the main power recovers normal, the ATS will transfer the load from the emergency power(generating set) to the main power, and then stop the emergency power(generating set.)

#### Optional 1-ATS without Cabinet ( Can be installed on the control panel Directly)

- Δ Small Size/Operator conveniently
- Δ ATS 63A-1100A with Economical Cost



#### Optional 2-ATS With Cabinet

- Δ Mains on lamp
- Δ Mains on load lamp
- Δ Gensets on lamp
- Δ Gensets on load lamp
- Δ Mode Transfer Switch
- Δ Emergency Stop
- Δ ATS 63A-3200A



### Sound Attenuated Enclosure/Option

#### Robust Corrosion Resistant Construction

- Δ Black finish stainless steel lock and hinges
- Δ Body made from steel components treated with

#### Excellent Access for Maintenance

- Δ Two large doors on each side
- Δ Radiator fill access plate
- Δ Lube oil and cooling water drains pipes to exterior of the enclosure

#### Security and Safety

- Δ Control panel viewing window in a lockable access door
- Δ Emergency stop push button (red) mounted on
- Δ Cooling fan and battery charging alternator fully
- Δ Exhaust silencing system totally enclosed for

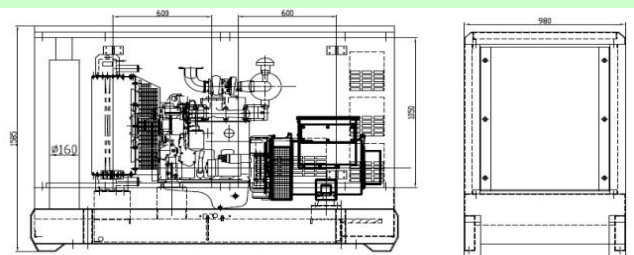
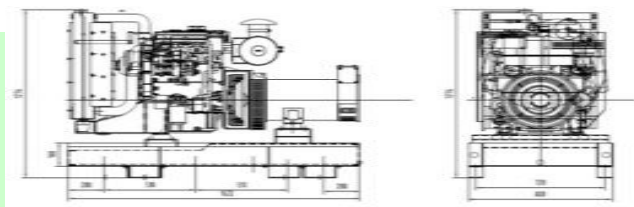

#### Dimensions and Weights-Open Type

Length (L)	Width (W)	Height (H)	Dry	Wet
mm	mm	mm	kg	kg
2700	1038	1680	2660	2710



## Dimensions and Weights-Canopy Type

Length (L)	Width (W)	Height (H)	Dry	Wet
mm	mm	mm	kg	kg
<b>3560</b>	<b>1220</b>	<b>1815</b>	<b>2760</b>	<b>2810</b>

## Sound Attenuated (SA) Sound Pressure Levels ( dBA)

7m (23ft)		1m (3ft)	
75%	100%	75%	100%
Load	Load	Load	Load
<b>76.9</b>	<b>77.8</b>	<b>77.9</b>	<b>79.7</b>



## General Information

### Wiring Diagram And Testing

A full set of operation and maintenance manuals and circuit wiring diagrams.

Ambient temperature: -25°C to 45°C. The coolant heater is needed when the temperature is below 5°C

Humidity: Less than 80%.

Inspection items

Protection devices working test

Starting ability in normal temperature

50% rated power load moment capability

Voltage deviation and speed variation: 0%, 25%, 50%,

The customer could also choose the color which the manufacturer offers

Offer a range of optional features to tailor our generator sets to meet your power needs.

### Options

50°C High Temperature ● Permanent Magnet Gen ● Auto Control Panel ● Daily Fuel Tank Radiator -erator (PMG) ● Auto Transfer Switch(ATS) ● Base Fuel Tank

Water Separator ● Anti Condensation Heater ● Trailer Type

Water Jacket Heater ● Drop CT(For Paralleling) ● Manual Paralleling System ● Automatic Input System For

Oil Heater ● Auto Paralleling System Fuel

Oil Discharging Pump ● Electronic Indicator for ● Maintenance Tools Fuel Level ● Accesory Bag