

Technical Data

2500 Series

2506D-E15TAG1

Diesel Engine - ElectropaK

Basic technical data

Number of cylinders	6
Cylinder arrangement	Vertical, In-line
Cycle	4 stroke
Induction system	turbocharged, air to air charge cooling
Combustion system	direct injection
Compression ratio	16:1
Bore	137 mm
Stroke	171 mm
Cubic capacity	15,2 litres
Direction of rotation	anti-clockwise viewed on flywheel
Firing order (cylinder 1 furthest from flywheel)	1, 5, 3, 6, 2, 4

Total weight of ElectropaK

-dry (engine only)	1633 kg
-wet	1714 kg

Overall dimensions of ElectropaK

-height	1718 mm
-length	2657 mm
-width	1120 mm

Moments of inertia (mk²)

Engine	2,3291 kgm ²
Flywheel	1,96355 kgm ²

Performance

Note: All data based on operation to ISO 3046/1, BS5514 and DIN 6271 standard reference conditions.

Cyclic irregularity

Engine / Flywheel maximum:	1:60
----------------------------	------

Ratings

Steady state stability at constant speed $\pm 0.25\%$
 Electrical ratings are based on average alternator efficiency and are for guidance only (0.8 power factor being used)

Operating point

Engine speed	1800 rev/min
Cooling water maximum exit temperature	< 107 °C

Fuel data

To conform to BS2869 class A2 or BS EN590

Test conditions

-air temperature	25 °C
-barometric pressure	100 kPa
-relative humidity	30%
-air inlet restriction at maximum power (nominal)	2,5 kPa
-exhaust back pressure at maximum power (nominal)	6,0 kPa
-maximum fuel temperature (inlet pump)	40 °C

Note: If the engine is to operate in ambient conditions other than those of the test conditions, suitable adjustments must be made for these changes. For full details, contact Perkins Technical Service Department. For test conditions relevant to data on load acceptance, refer to the bottom of page 12.

Sound level

Estimated sound pressure at 1 metre	105,2 dB(A)
-------------------------------------	-------------

General installation

Designation	Units	Type of operation and application	
		Prime	Standby
		60 Hz @ 1800 rev/min	
Gross engine power	kWb	458	514
Fan power	kWm	15.5	
Restriction losses	kWm	8	8,9
ElectropaK nett engine power	kWm	435	490
Gross brake mean effective pressure	kPa	2036	2284
Combustion air flow	m ³ /min	39.3	41,5
Exhaust gas temperature (max)	°C	N/A	550
Exhaust gas flow	m ³ /min	104,5	112
Boost pressure ratio	-	3,26	3,43
Overall thermal efficiency (nett)	%	37,4	38,1
Friction and pumping power losses	kWm	51	
Mean piston speed	m/s	10	
Engine coolant flow	l/min	7,2	
Cooling fan air flow (zero duct allowance)	m ³ /min	866	
Typical Gen Set electrical output (0.8 pf)	kWe	400	450
	kVA	500	563
Assumed alternator efficiency	%	92	

Rating definitions

Prime power

Variable load. Unlimited hours usage with an average load factor of 80% of the published Prime Power rating over each 24 hour period. A 10% overload is available for 1 hour in every 12 hours operation

Standby power

Variable load. Limited to 500 hours annual usage up to 300 hours of which may be continuous running. No overload is permitted

Emissions capability

Certified against the requirements of Tier 3 legislation for non-road mobile machinery, powered by constant speed engines (EPA 40 CFR Part 89 Tier 3).

Energy balance

Designation	Units	Type of operation and application	
		Prime	Standby
		60 Hz @ 1800 rev/min	
Energy in fuel	kWt	1200	1320
Energy in power output (gross)	kWb	458	514
Energy to cooling fan and restrictions	kWm	23,5	24,4
Energy in power output (nett)	kWm	435	490
Energy to exhaust	kWt	420	465
Energy to coolant and oil	kWt	170	178
Energy to radiation	kWt	38	35
Energy to charge cooler	kWt	114	128

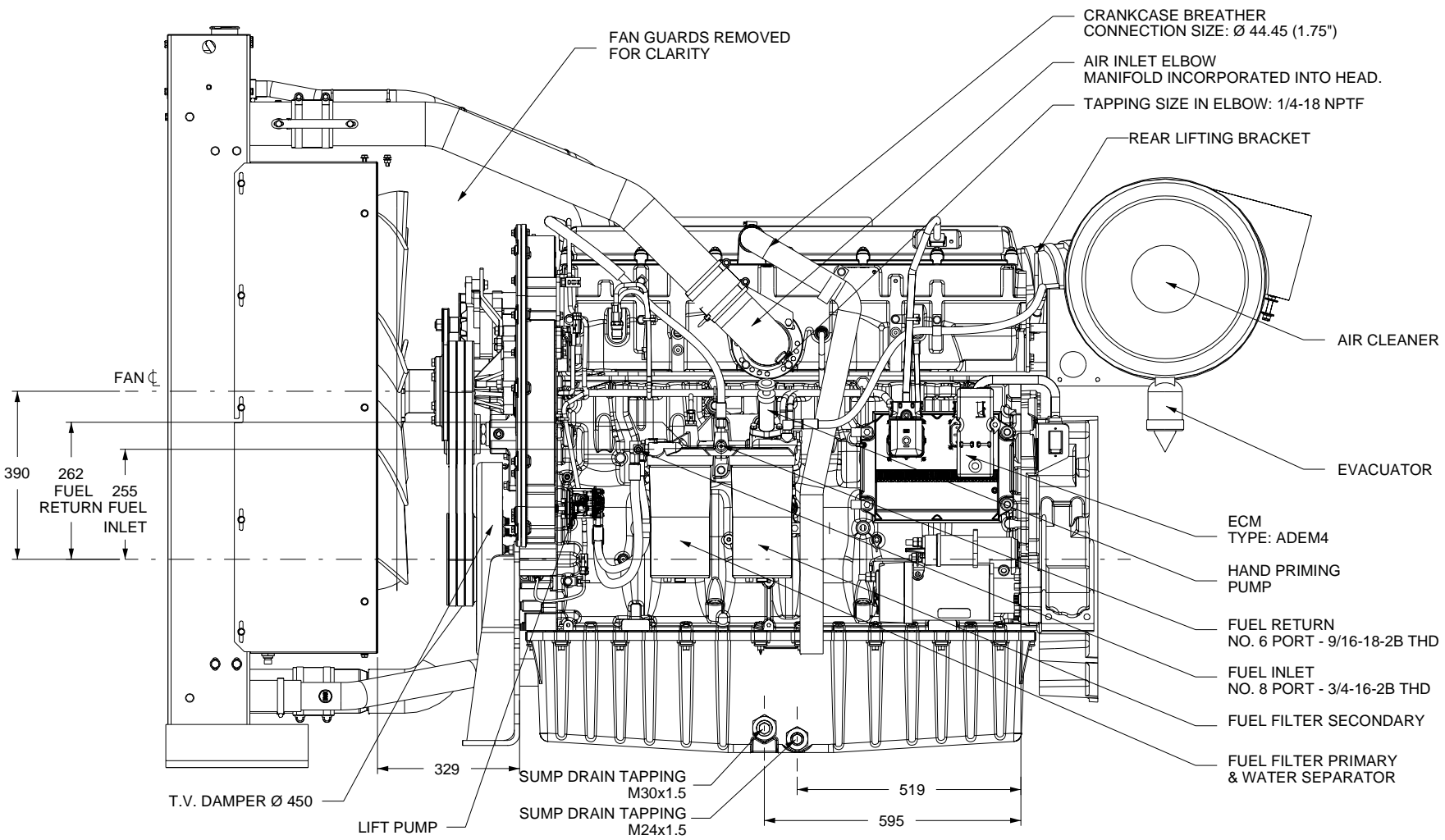

Note: This drawing is for reference only. For installation purposes, please refer to the relevant General Installation drawing (Z13579).

2506D-E15TAG1 - front view

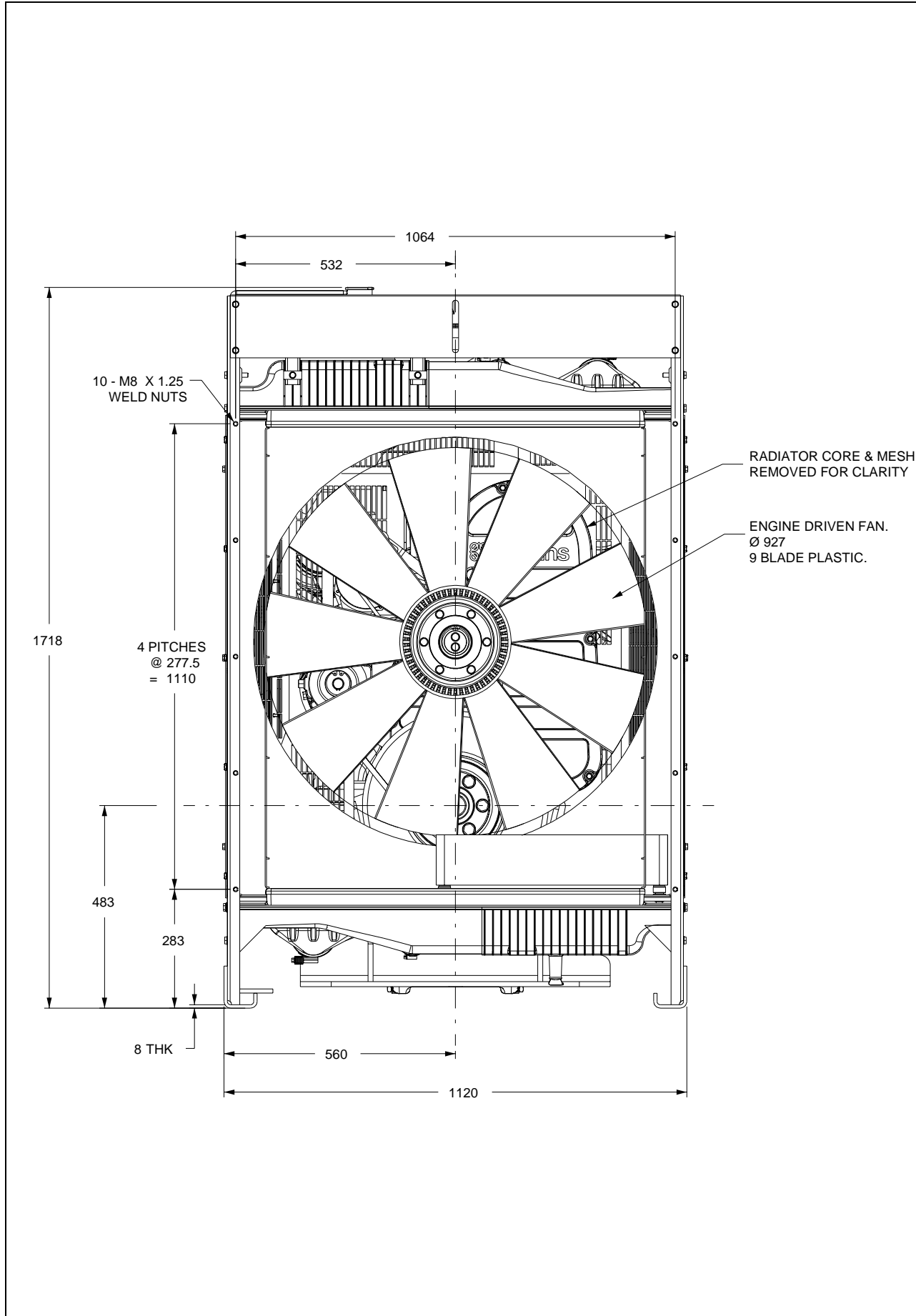

Note: This drawing is for reference only. For installation purposes, please refer to the relevant General Installation drawing (Z13579).

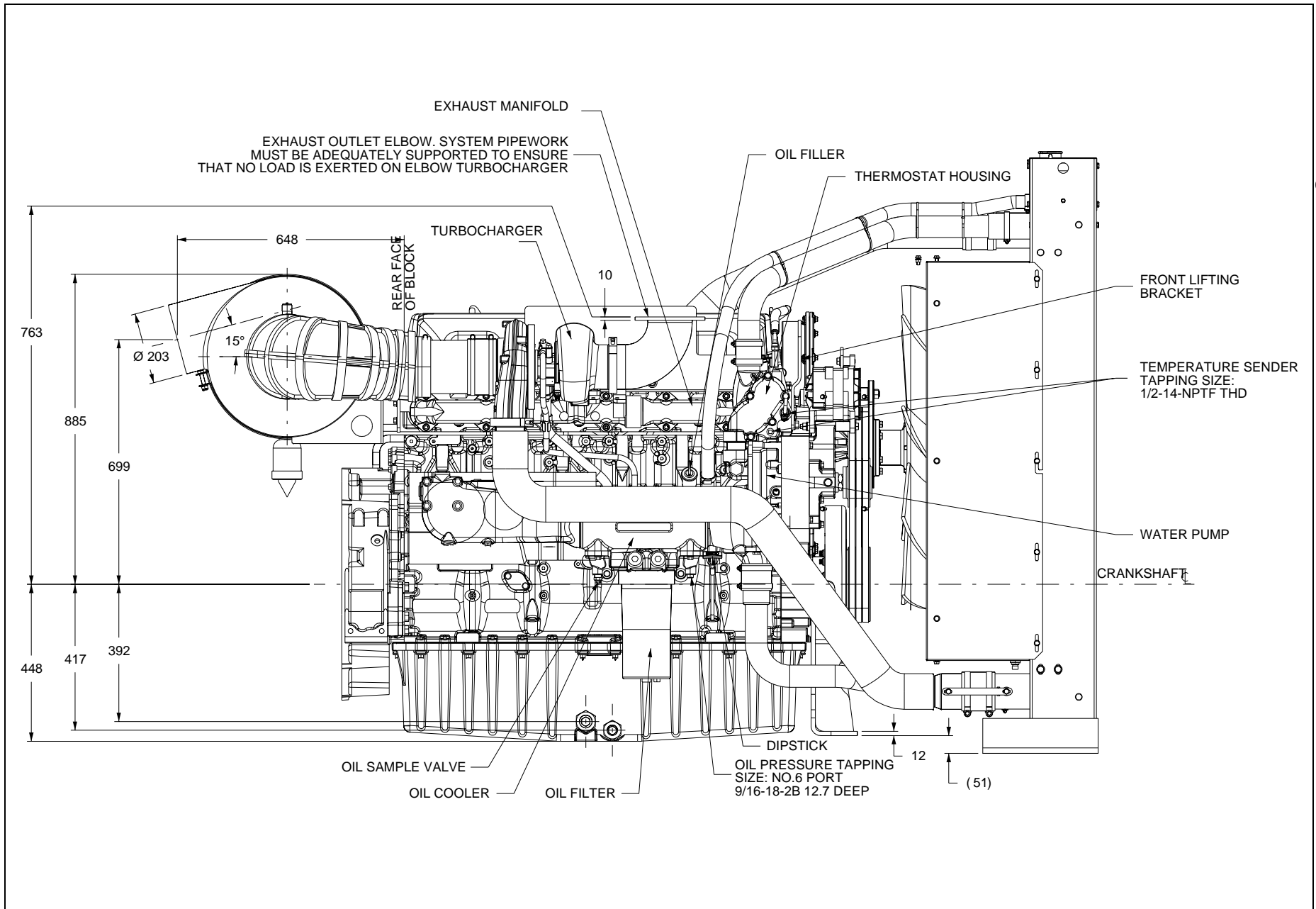

Note: This drawing is for reference only. For installation purposes, please refer to the relevant General Installation drawing (Z13579).

2506D-E15TAG1 - rear view

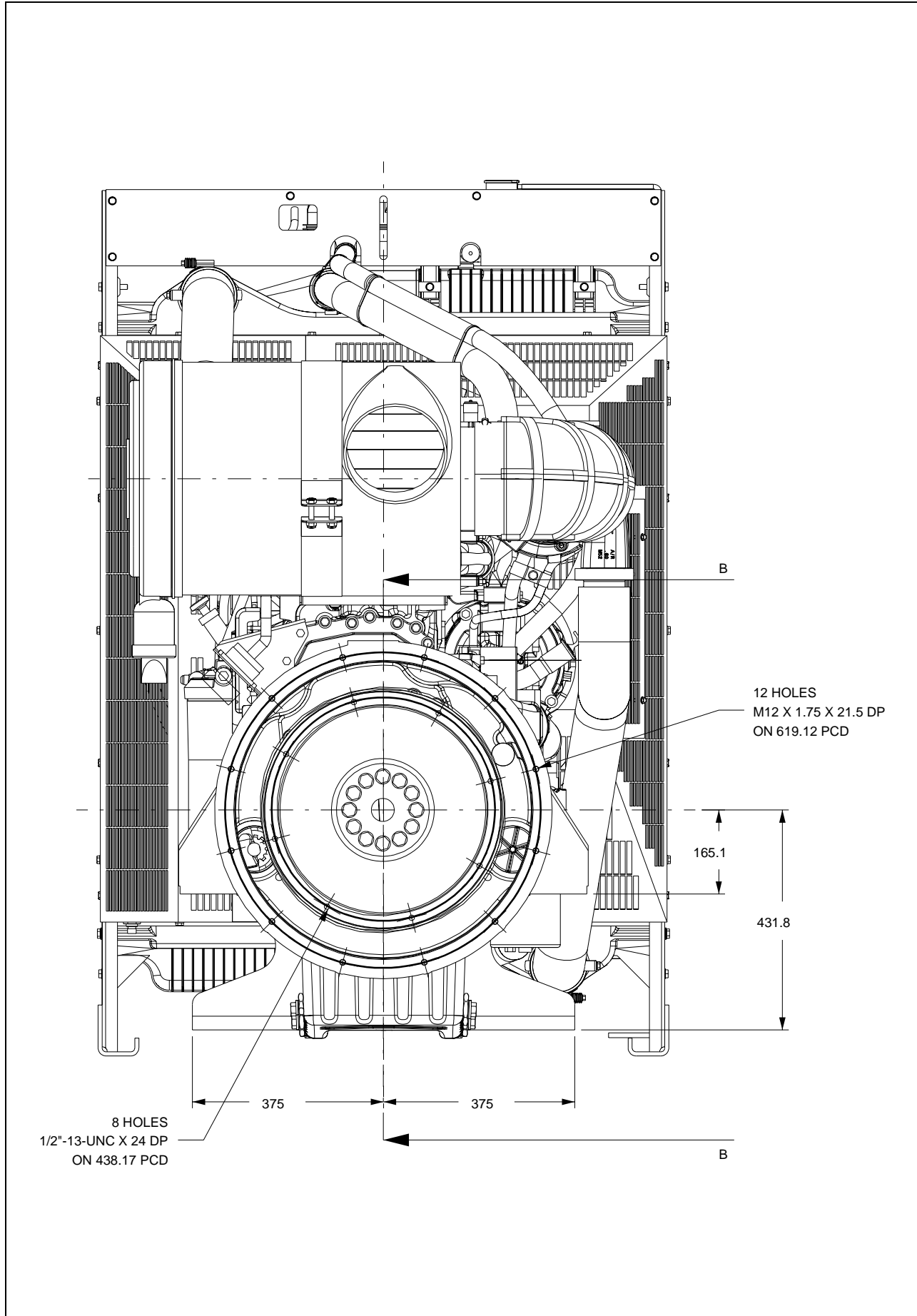

Note: This drawing is for reference only. For installation purposes, please refer to the relevant General Installation drawing (Z13579).

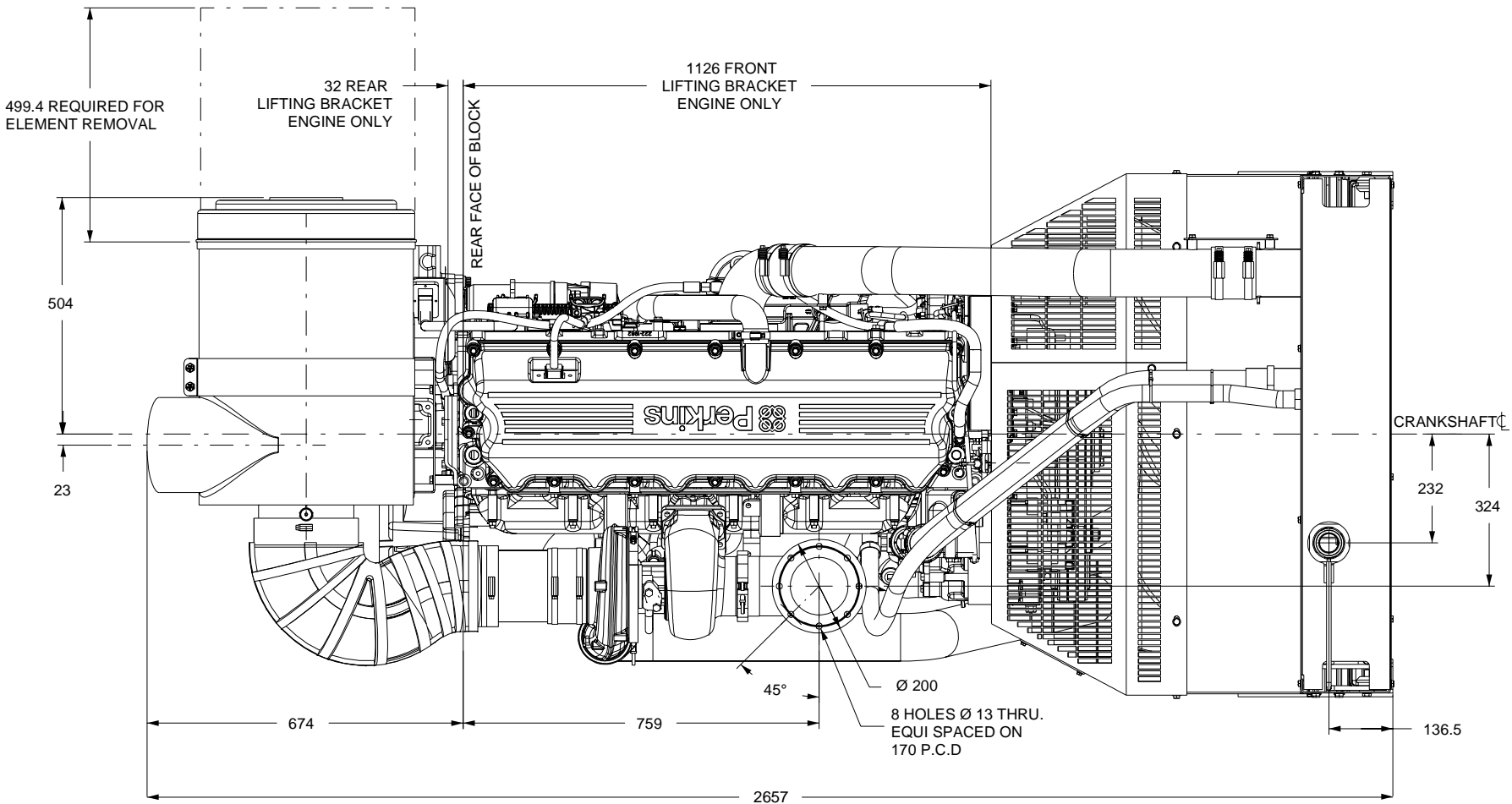

Note: This drawing is for reference only. For installation purposes, please refer to the relevant General Installation drawing (Z13579).

2506D-E15TAG1 - miscellaneous views

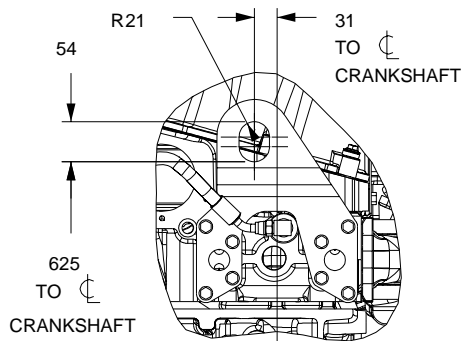

**SCRAP VIEW SHOWING
DETAILS OF REAR LIFTING
EYE**

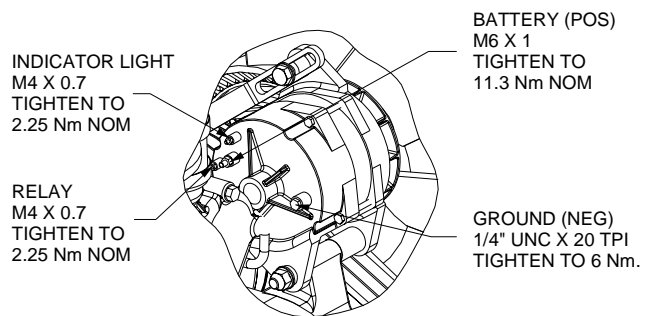

**SCRAP VIEW SHOWING ALTERNATOR CONNECTIONS.
FAN GUARDS & THERMOSTAT REMOVED FOR CLARITY.
SCALE 1:3**

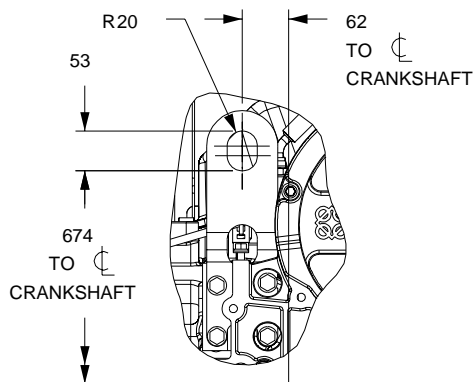

**SCRAP VIEW SHOWING
DETAILS OF FRONT LIFTING
EYE**

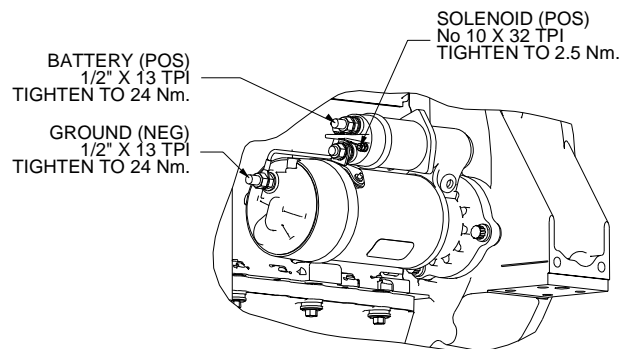

**SCRAP VIEW SHOWING
STARTER MOTOR CONNECTIONS
SCALE 1:3**

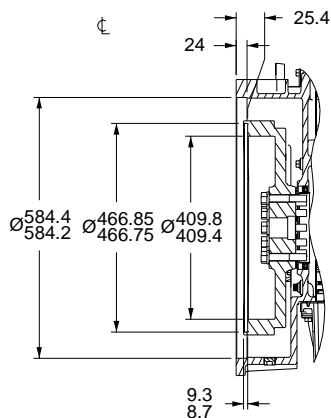

**SECTION B-B
DETAILS OF SAE 1 / 2 FLYWHEEL HOUSING
AND SAE J620 SIZE 14 FLYWHEEL**

Note: This drawing is for reference only. For installation purposes, please refer to the relevant General Installation drawing (Z13579).

Cooling system

Recommended coolant:

50% inhibited ethylene glycol or 50% inhibited propylene glycol and 50% clean fresh water. Where there is no likelihood of ambient temperatures below 10 °C, clean 'soft' water may be used, treated with 1% by volume of Perkins inhibitor in the cooling system. The inhibitor is available from all Perkins Distributors.

Total system coolant capacity ... 58,0 litres
 Maximum pressure:
 -in crankcase water jacket ... 276 kPa
 Maximum top tank temperature ... 107 °C
 Maximum static pressure on pump ... 170 kPa
 Maximum permissible restriction:
 -to coolant pump flow ... 30 kPa
 Temperature rise across engine with inhibited coolant
 -standby power ... 10 °C
 -prime power ... 9 °C
 Thermostat operation range ... 88 to 98 °C

Radiator

-face area ... 1.238 m²
 -weight (dry) ... 132 kg
 -rows and materials ... 2 rows, Aluminium
 -matrix density and material ... 12 fins per inch, Aluminium
 -width of matrix ... 1048 mm
 -height of matrix ... 1100 mm
 -pressure cap setting (minimum) ... 69 kPa

Charge cooler with integral radiator

-face area ... 1.006 m²
 -number of rows and material ... 1 row, Aluminium
 -matrix density and material ... 12,5 fins per inch, Aluminium
 -width of matrix ... 915 mm
 -height of matrix ... 1100 mm

Coolant pump

Speed: ... 1946 rev/min
 Method of drive ... gear

Fan

-diameter ... 927 mm
 -drive ratio ... 0.92:1
 -number of blades ... 9
 -material ... B3WG6 or PA6GF30 Nylon 6 glass filled 30%
 -type ... ACS 367500

Cooling clearance

Ambient cooling clearance (standby power) based on air temperature at fan of 6 °C above the ambient

2506D-E15TAG1 maximum additional restriction (duct allowance) to cooling airflow and resultant minimum airflow			
Duct allowance with inhibited coolant at 50 °C			
Description	rev/min	Units	Standby
Duct allowance	1800	kPa	0.125
Minimum airflow	1800	m ³ /min	822
Duct allowance with 50% glycol at 43 °C			
Duct allowance	1800	kPa	0.200
Minimum airflow	1800	m ³ /min	792

Electrical system

Type ... 12V negative earth
 Alternator
 -type ... 22SI
 -voltage ... 24 volts
 -output ... 70 amps
 Starter
 -type ... 42MT
 -motor voltage ... 24 volts
 -motor power ... 7,5 kW
 Number of teeth
 -on the flywheel ... 113
 -on starter pinion ... 11
 Minimum cranking speed ... 100 rev/min
 Pull-in current of starter motor solenoid
 @ -25 °C max ⁽¹⁾ ... 57 amps
 Hold-in current of starter motor solenoid
 @ -25 °C max ⁽¹⁾ ... 16 amps

1. All leads to rated at 10 amps minimum

Cold start recommendations

Temperature Range	
5 to -10 °C (41 to 14 °F)	Oil: 15W40 Starter: 42MT Battery: 2x 12V 128 Ah Max breakaway current: 1250 amps Cranking current: 676 amps Aids: None Minimum mean cranking speed: 120 rev/min

Temperature Range	
-11 to -25 °C (12.2 to -13 °F)	Oil: 0W40 Starter: 42MT Battery: 2x 12V 128 Ah Max breakaway current: 1250 amps Cranking current: 880 amps Aids: block heater 1.5 kW Minimum mean cranking speed: 120 rev/min

- Battery capacity is defined by the 20 hour rate
- The oil specification should be for the minimum ambient temperature as the oil will not be warmed by the immersion heater
- Breakaway current is dependent on battery capacity available. Cables should be capable of handling the transient current which may be up to double the steady cranking current.

Exhaust system

Maximum back pressure 6,8 kPa

Exhaust outlet size (internal). 150 mm

Recommended exhaust pipe diameter

length	mm
up to 10m	150
10m to 20m	150
20m to 30m	200

Fuel system

Type of injection MEUI

Injector type MEUI

Injector pressure. 200 MPa

Fuel lift pump

type. gear driven

Delivery flow 457 litres/hr

Pressure 550 kPa

Maximum suction head at pump inlet. 3 m

Maximum static pressure head 4 m

Fuel inlet temperature to be less than 55 °C

Governor type. electronic

Governing to ISO 8528-5 class G3 steady state

Fuel filtration level

-primary 10 µm

-secondary 2 µm

Fuel consumption

Designation	Fuel consumption calculated on nett rated powers	
	g/kWh	litres/hr
	1800 rev/min	
Standby	222	126
Prime + 10%	222	126
Prime	225	113
At 75% of Prime	245	93
At 50% of Prime	267	67

Induction system

Maximum air intake restriction

- clean filter 3,7 kPa
- dirty filter 6,2 kPa
- air filter type paper element 457 mm diameter

Lubrication system

The recommended SAE viscosity is a multigrade oil (15W40) which adequately meets the specifications of API C14

- Total system capacity 62,0 litres
- Maximum sump capacity 53,0 litres
- Minimum sump capacity 45,0 litres

Lubricating oil pressure

- at rated speed... 420 kPa
- Nominal (minimum) 200 kPa
- Oil relief valve opens.. 620 kPa
- Oil filter screen spacing.. 30 µm
- Sump drain plug tapping size. M24
- Oil pump speed and drive method 1,16 x engine speed, gear
- Oil flow 3,5 litres/sec
- Oil consumption at full load rated speed
(as a percentage of fuel consumption)... 0,1%
- Oil temperature (in rail)
- maximum continuous operation 114 °C

Normal operating angles

- front and rear 7°
- side tilt... 7°

Recommended SAE viscosity

A single or multigrade oil must be used which conforms API C14 or ACEA E5.

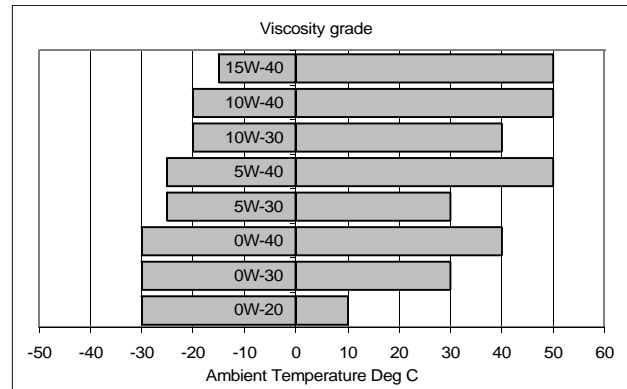

Mountings

- Maximum static bending moment at rear face of block. 1356 Nm

Centre of gravity (bare dry engine)

- forward of rear face of cylinder block 570 mm
- above crankshaft centre line 240 mm

Engine management system

Full electronic engine management system controlling:

- speed governing
- air / fuel ratio
- start / stop sequence
- engine protection and diagnostics

Typical load acceptance

Model / Engine speed	Initial Load Acceptance When engine reaches rated speed (15 seconds maximum after engine starts to crank)				2nd Load Application Immediately after engine has recovered to rated speed (5 seconds after initial load application)			
	Prime Power %	Load kWm (kWe) Nett	Transient Frequency Deviation %	Frequency recovery time seconds	Prime Power %	Load kWm (kWe) Nett	Transient Frequency Deviation %	Frequency recovery time seconds
1800 rev/min	65	266	≤10	5	60	245	≤10	5

The above figures were obtained under test conditions as follows:

- Engine block temperature..... 45 °C
- Ambient temperature..... 15 °C
- Governing mode..... Isochronous
- Alternator inertia..... 8 kgm²
- Under frequency roll off (UFRO) point set to..... 1 Hz below rated frequency
- UFRO rate set to..... 2 % voltage / 1% frequency
- LAM on / off..... off

All tests were conducted using an engine installed and serviced to Perkins Engines Company Limited recommendations.

The applied load is a percentage of generator electrical output, using alternator efficiencies as published in the general installation section of this Technical Data Sheet.

The information given on this Technical Data Sheet is for standard ratings only. For ratings other than those shown, please contact Perkins Engines Company Limited, Stafford.

The information given in this document is for guidance only.



Perkins Engines Company Limited
 Peterborough PE1 5NA United Kingdom
 Telephone +44 (0) 1733 583000
 Fax +44 (0) 1733 582240
 www.perkins.com

Distributed by

All information in the document is substantially correct at the time of printing but may be subsequently altered by the company.