

Technical Data

1300 Series EDi

1306C-E87TAG3

ElectropaK

205 kW @ 1500 rev/min

Basic technical data

Rating code M158
Switchable rating code (with 227 kW @ 1800 rev/min) M167
 Number of cylinders 6
 Cylinder arrangement Vertical, in-line
 Cycle Four stroke
 Induction system Air to air charged cooled, turbocharged
 Compression ratio 16.9 : 1
 Bore 116,6 mm (4.59 in)
 Stroke 135,9 mm (5.35 in)
 Cubic capacity 8,7 litres (531 in³)
 Direction of rotation Clockwise, from the front
 Firing order 1, 5, 3, 6, 2, 4
 Engine weight (1), (2) (dry) 671 kg (1479 lb)
 Engine weight (1), (2) (wet) 698 kg (1538 lb)
 Weight of ElectropaK kit (3) (inc. radiator; fan; fan-guards; starter motor; alternator and air filter assembly) 225 kg (496 lb)
 (1) Includes SAE 2 flywheel and flywheel housing
 (2) Without ElectropaK kit
 (3) Does not include weight of radiator coolant

Overall dimensions (includes ElectropaK kit)

-height 1369 mm (54 in)
 -length 1822 mm (72 in)
 -width (including mounting brackets) 875 mm (34.4 in)

Moments of inertia (mk²)

-engine 0,536 kgf m² (1830.8 lbf in²)
 -flywheel SAE 2 (option GL08) 1,005 kgf m² (3435 lbf in²)

Centre of gravity

Position of centre (dry, base engine)
 -forward from rear of block 480,1 mm (18.9 in)
 -above centre line of block 185,4 mm (7.3 in)
 -offset to Rhs of centre line 25,4 mm (1 in)

Position of centre (dry, base engine plus accessories)

-forward from rear of block 449,6 mm (17.7 in)
 -above centre line of block 182,9 mm (7.2 in)
 -offset to Rhs of centre line 10,2 mm (0.4 in)

Moments of inertia (mk²)

-engine 0,536 kgf m² (1830.8 lbf in²)
 -flywheel SAE 2 (option GL08) 1,005 kgf m² (3435 lbf in²)

Performance

All data based on ISO/TR 14396; SAE J1995 3.1;
 ISO3046/1; DIN6271

Engine speed control in

accordance with BS5514 pt.4; ISO3046-4 and ISO8528-5

Cyclic irregularity

-at 110% stand-by power TBA

Test conditions

-air temperature 25 °C (77 °F)
 -barometric pressure 100 kPa (29.61 in hg)
 -relative humidity 30%

Sound level

-bare engine at 1 metre TBA dBA
 -all ratings certified to within +3 % to -5 %

If the engine is to operate in ambient conditions other than those of the test conditions, suitable adjustments must be made for these changes. For full details, contact Perkins Technical Service Department.

Start/load delay: For ambient temperatures above 15 °C (59 °F), prime power can start to be applied after the starter motor is engaged in increments in accordance with ISO 8528-5. If the ambient temperature is less than 15 °C (59 °F), an immersion heater is recommended. For additional information, contact Perkins Technical Service Department.

General installation

Designation	Units	Type of operation and application		
		Base	Prime	Stand-by
		50Hz	50Hz	50Hz
Gross engine power	kW (bhp)	169 (227)	186 (250)	205 (275)
Brake mean effective pressure	kPa (lbf/in ²)	1529 (222)	1683 (244)	1855 (269)
Mean piston speed	m/s (ft/s)	6,8 (22.3)	6,8 (22.3)	6,8 (22.3)
ElectropaK net engine power	kW (bhp)	164 (220)	180 (243)	199 (267)
Engine coolant flow	l/min (UK gal/min)	293 (64.5)	293 (64.5)	293 (64.5)
Combustion air flow	m ³ /min (ft ³ /min)	-	-	13,5 (477)
Exhaust gas flow (max)	m ³ /min (ft ³ /min)	-	-	36,5 (1290)
Exhaust gas temperature (max)	°C (°F)	-	-	524 (975)
Cooling fan air flow	m ³ /min (ft ³ /min)	375 (13241)	375 (13241)	375 (13241)
Energy balance				
Energy in fuel (Fuel heat of combustion)	kW (Btu/min)	-	440 (25042)	482 (27433)
Gross heat to power	kW (Btu/min)	169 (9619)	186 (10586)	205 (11668)
Energy in power output (net)	kW (Btu/min)	164 (9334)	180 (10245)	199 (11326)
Energy to coolant and lubricating oil	kW (Btu/min)	-	-	90 (5122)
Energy to exhaust	kW (Btu/min)	-	-	122 (6944)
Heat to radiation	kW (Btu/min)	-	-	36 (2049)

Caution: The airflows shown in this table will provide acceptable cooling for an open power unit operating in ambient temperatures of up to 53 °C (127.4 °F) 46 °C (114.8 °F) if a canopy is fitted. If the power unit is to be enclosed totally, a cooling test should be done to check that the engine cooling is acceptable. If there is insufficient cooling, contact Perkins Technical Service Department.

1306C-E87TAG3 ElectropaK, left side view

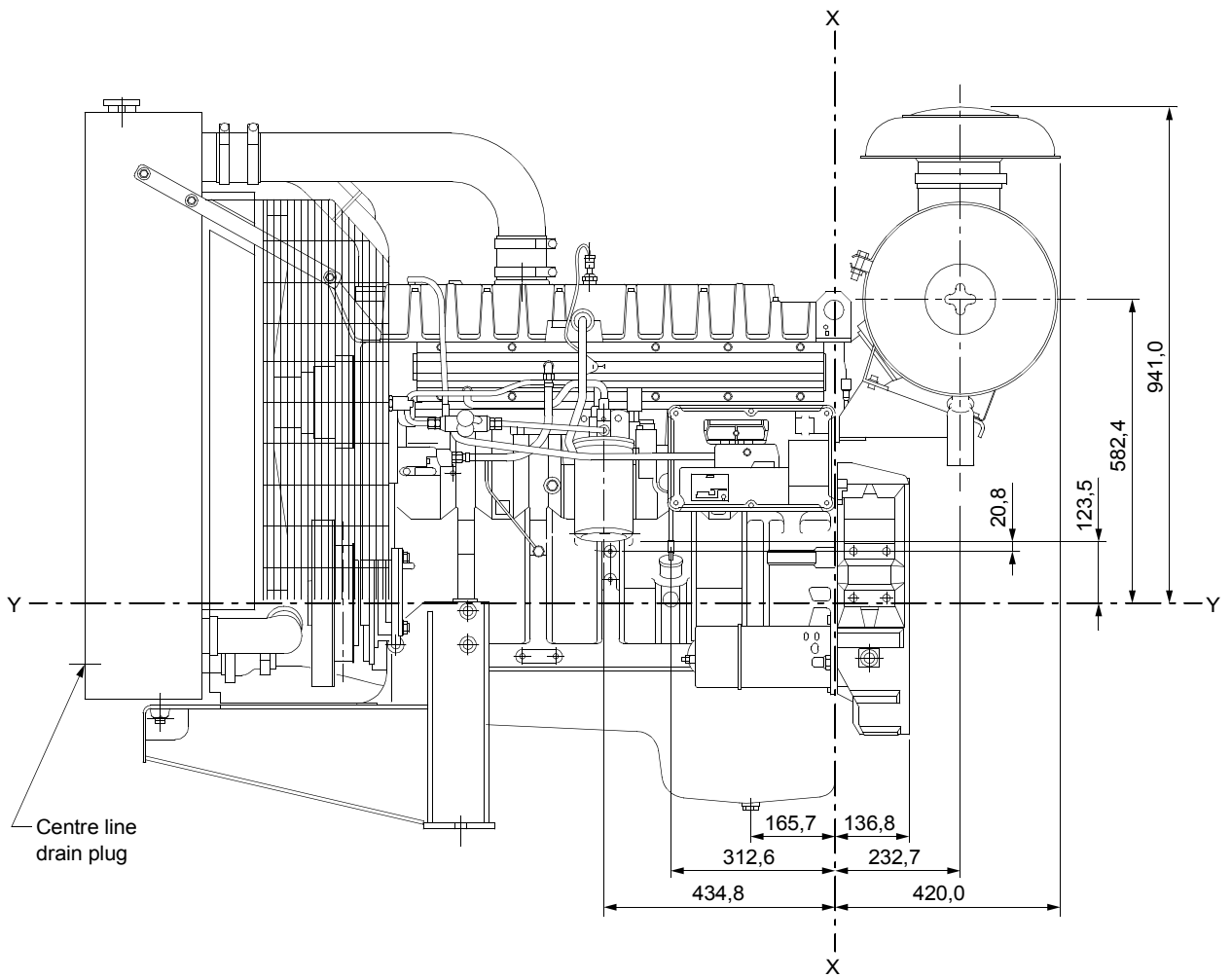

1306C-E87TAG3 ElectropaK, right side view

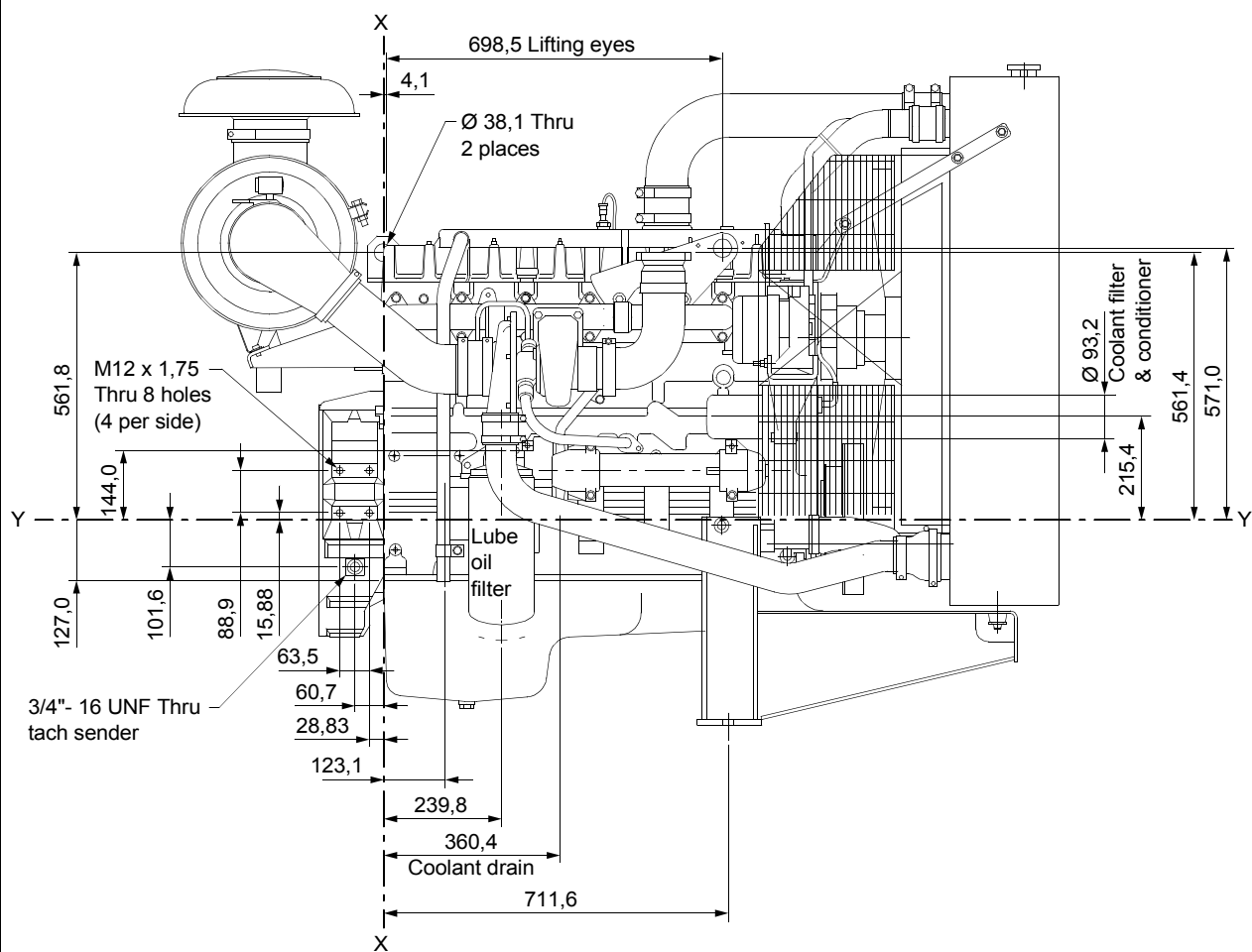

1306C-E87TAG3 ElectropaK, front and rear views

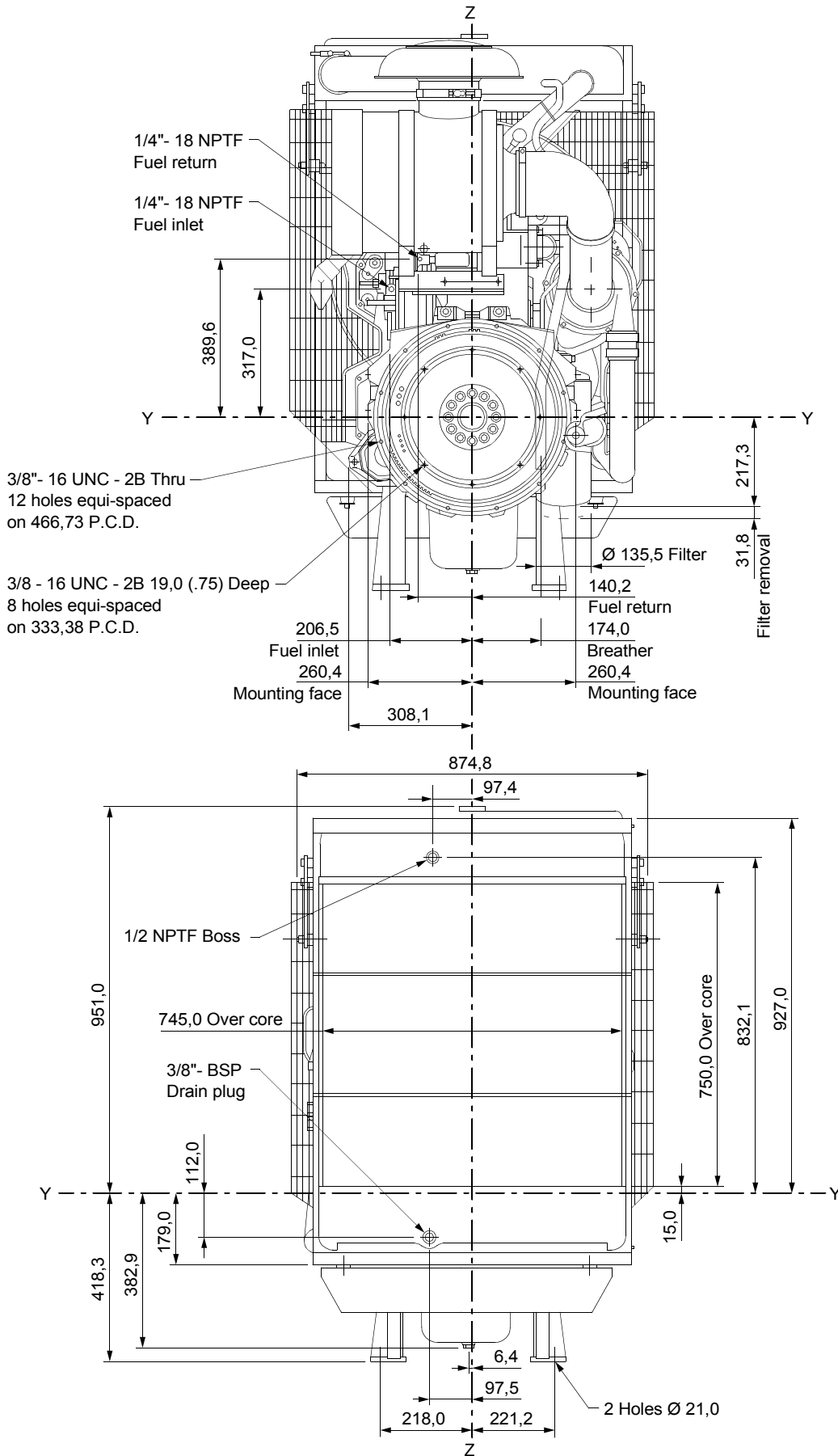

1306C-E87TAG3 ElectropaK, plan view

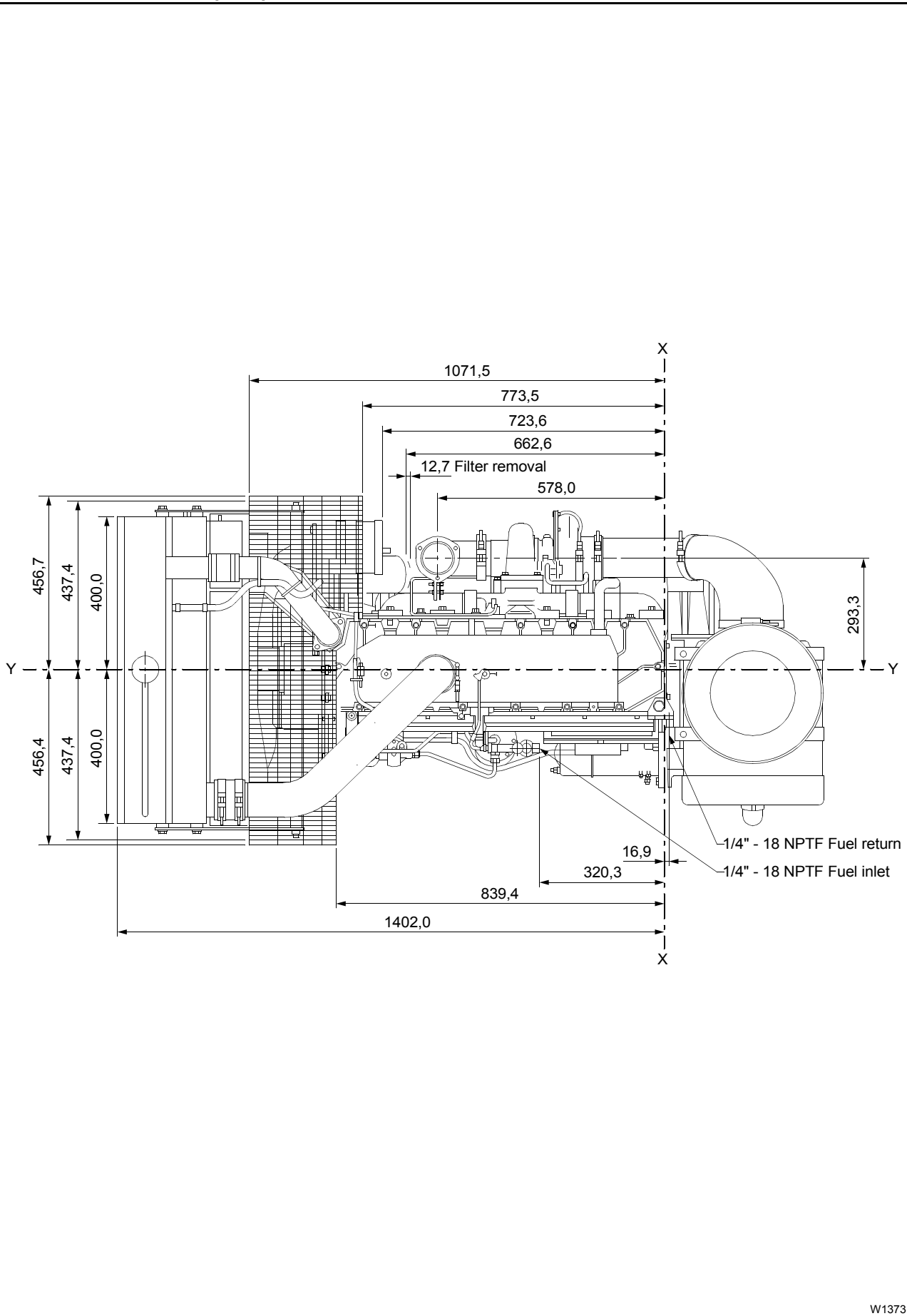

Cooling system

Radiator

- face area ... 0,6 m² (930 in²)
- rows and materials ... 3, brass
- matrix density and material ... 12, copper
- width of matrix ... 745 mm (29.3 in)
- height of matrix ... 750 mm (29.5 in)
- pressure cap setting ... 68,9 kPa (10 lbf/in²)
- Estimated cooling air flow reserve ... 0,13 kPa (0.019 lbf/in²)

Fan

- diameter ... 711,2 mm (28 in)
- drive ratio ... 1:2 : 1
- number of blades ... 7
- material ... Plastic
- type ... Pusher

Coolant

- Maximum pressure head at pump ... 12,95 m (42.5 ft)
- Total system capacity
- with radiator ... 37,2 litres (65.5 UK pints)
- without radiator ... 12,8 litres (22.55 UK pints)
- draindown capacity ... 1,3 litres (2.3 UK pints)
- Maximum top tank temperature ... 103 °C (218 °F)
- Minimum temperature to engine ... 79 °C (175 °F)
- Temperature rise across engine ... 5 °C (41 °F)
- Max permissible external system resistance ... 35 kPa (5 lbf/in²)
- Thermostat start to open ... 87,8 °C (190 °F)
- Thermostat fully open ... 96,1 °C (205 °F)

Electrical System

- type ... Negative ground
- alternator ... 12/24V Lucas AC5R
- starter motor ... 12V Lucas PE129 / 24V Lucas S115

Cold start recommendations

Minimum cranking speed ... 130 rev/min

Minimum starting temperature		Grade of engine lubricating oil	Battery specifications			
			BS3911 Cold start amps	SAEJ537 Cold cranking amps	Number of batteries needed	Perkins type
°C	°F					
-15	5	10W	440	660	2	A
-20	4	5W	440	660	2	A

Exhaust system

Maximum back pressure ... 10,7 kPa (3.2 in Hg)

Note: For exhaust pipe details, see chapter five of the Gen Set Manual.

Fuel system

- Type of injection ... Direct
- Fuel feed pump ... Bosch
- Hydraulic pump ... Rexroth
- Fuel atomiser ... Heui
- Feed pump operating pressure ... 417 kPa (60 lbf/in²)

Fuel lift pump

- flow/hour ... 180 litres/hr (39.59 UK gals/hr)
- suction depression ... 14 kPa (2 lbf/in²)
- pressure ... 137,9 kPa (20 lbf/in²)
- Maximum suction head ... 1 m (3.28 ft)
- Maximum static pressure head ... 3 m (9.84 ft)
- Maximum fuel pump suction (clean system) ... 14 kPa (4 in hg)

Governor type ... electronic (isochronous or droop capability)
 -speed control for diesel fuel to conform to ... BS 2869 Class A2
 ... ASTM D975 66T Number 2D

Fuel specification

Fuel specification	USA Fed Off Highway EPA 2D 89.330-96
Density (kg/l @ 15 °C)	0,845 - 0,85
Viscosity (mm ² /s @ 40 °C)	2,0 - 3,2
Sulphur Content	0.03 - 0.05%
Cetane Number	40 - 48

Fuel consumption

- at rated speed ... 49,1 litres/hr (10.8 UK gal/hr)

Induction system

Maximum air intake restriction

- clean filter ... 2,5 kPa (0.36 lbf/in²)
- dirty filter ... 6,22 kPa (0.9 lbf/in²)
- air filter type ... dry paper element
- Turbocharger type ... Allied signal

Lubrication system

Lubricating oil capacity:

- dry engine with filter ... 28,3 litres
- oil change with filter ... 26,4 litres
- oil change without filter ... 22,7 litres

Maximum engine operating angles

-front up, front down, right side or left side ... 30°

Lubricating oil pressure

- relief valve opens ... 552 kPa (80 lbf/in²)
- at low idle (700 rev/min) ... 103 kPa (15 lbf/in²)
- at high idle speed ... 276 - 483 kPa (40 - 70 lbf/in²)
- Normal oil temperature (sump) ... 121 °C (250 °F)
- Oil consumption at full load as a % of fuel consumption <0.1%

Recommended SAE viscosity

A single or multigrade oil must be used which conforms to API-CH-4, API-CG-4 or ACEA E3 (if not available, use only API-CF-4 or ACEA E2) see illustration below:

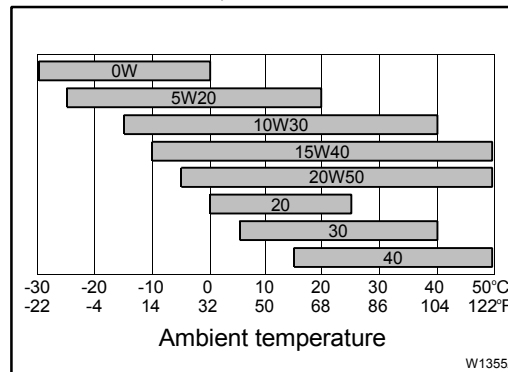

Mountings

Maximum static bending moment at rear face of block ... 2644 Nm (1950 lbf ft)

@ Perkins

Perkins Engines Company Limited

Peterborough PE1 5NA United Kingdom
 Telephone +44 (0) 1733 583000
 Fax +44 (0) 1733 582240
 www.perkins.com

Distributed by

All information in the document is substantially correct at the time of printing but may be subsequently altered by the company.