

Technical Data

1200 Series

1206E-E70TTA

Electropak

200 kWe @ 1800 rpm

Basic technical data

Number of cylinders 6
 Cylinder arrangement Vertical in-line
 Cycle 4 stroke
 Induction system Series turbocharged charge cooled
 Combustion system Direct injection (DI)
 Compression ratio 16.5:1
 Bore 105 mm (4.13 in)
 Stroke 135 mm (5.31 in)
 Displacement 7.01 litres (427.8 in³)
 Direction of rotation when viewed from flywheel Anti-clockwise
 Direction of rotation when viewed from front Clockwise
 Firing order 1, 5, 3, 6, 2, 4
 Lifting points location Baseframe
 Mobile use g-load limitations 6g
 -est. total weight (dry) Including radiator support brackets . 1258 kg
 -est. total weight (wet) Including radiator support brackets 1295 kg

Overall dimensions

-height, including radiator support brackets 1617 mm
 -length, front of radiator to rear of air cleaner 1902 mm
 -width 916 mm

Moments of inertia (mk²)

Engine rotational components 0.18255 kgm²
 Crank pulley 0.01555 kgm²
 Flywheel (D0004) SAE 3 1.2 kgm²
 Flywheel (D0094) SAE 2 0.89 kgm²
 Flywheel (D0093) SAE 1 2.05 kgm²

Centre of gravity

Forward from rear of block - wet 445.3 mm
 Above crankshaft centre line - wet 253.2 mm
 Offset to RHS of crankshaft centre line - wet 8.8 mm

Centre of gravity of engine

Forward from rear of block - wet 393 mm
 Above crankshaft centre line - wet 182 mm
 Offset to RHS of crankshaft centre line - wet 30 mm

Performance

Note: All performance data based on operation to ISO Standard reference: TR 14396.

All ratings certified to within ± 3%
 Speed variation at constant load ±0.25%

Test conditions

Air temperature 25°C
 Barometric pressure 100 kPa
 Relative humidity 10.7 %
 Air inlet restriction at maximum power (nominal) 5.0 kPa
 Exhaust back pressure at maximum power (nominal) 35.0 kPa

Fuel temperature (inlet pump) 80.0°C

Noise data

Radiated Sound Power Levels (dB(A) ref. 1pW)	@ 1800 rpm
At rated speed with pusher fan	117 dB(A)

Note: If the engine is to operate in ambient conditions other than those of the test conditions, suitable adjustments must be made for these changes.
 For full details, contact Perkins Technical Service Department.

Emissions statement:

De-rate curves for altitude, humidity and temperature.

General installation

	Units	Prime	Standby
Gross engine power (sales power)	kWm	217.0	239.1
Fan and battery charging alternator power	kW	16.0	
Cooling fan airflow at zero duct - Dia 724mm pusher (including engine and core resistance)	m ³ /sec	13.6	14.3
Radiator core resistance	Pa		
Fan power absorption	kWm	16.0	
Net engine power - full battery	kWm	201.0	223.0
Torque gross	Nm	1151	1266
Brake mean effective pressure	kPa	2036	2270
Inlet air flow volume - wet	m ³ /min	15.8	16.7
Exhaust gas flow - wet	m ³ /min	13	14
Exhaust gas mass flow - wet	kg/sec	17	17
Exhaust gas temperature maximum after turbocharger	°C		506.0
Exhaust gas flow (max)	m ³ /min	13.1	
Boost pressure ratio	:1	N/A	
Overall thermal efficiency (net)	%	N/A	
Assumed alternator efficiency	%	92	
Regenerative power estimated	kW	N/A	N/A
Engine coolant flow - minimum	l/s	4.9	
Typical GenSet electrical output (0.8pf)	kVA	227.5	250
	kWe	182.0	200.0

Caution: The airflows shown in this table will provide acceptable cooling for an open power unit operating in ambient temperatures of up to 55°C (131°F) or 48°C (118.4°F) if a canopy is fitted with an air flow restriction of up to 120 Pa. If the power unit is to be enclosed totally, a cooling test should be done to check that the engine cooling is acceptable. If there is insufficient cooling, contact Perkins Technical Service Department.

Energy balance

Designation	Units	Prime	Standby
Energy in fuel (fuel heat of combustion)	kWt	637.0	708.0
Energy to power (gross)	kWt	217.0	239.0
Energy to cooling fan - pusher	kWm	16.0	
Energy to power (nett)	kWm	201.0	223.0
Heat rejection to radiator	kWt	127.0	144.0
Energy to exhaust	kWt	223.0	248.0
Energy to charge cooler	kWt	43.0	45.0
Energy to radiation	kWt	27.0	31.0

Energy balance referenced to absolute 0 Kelvin.

200 kW_e @ 1800 rpm - left side view

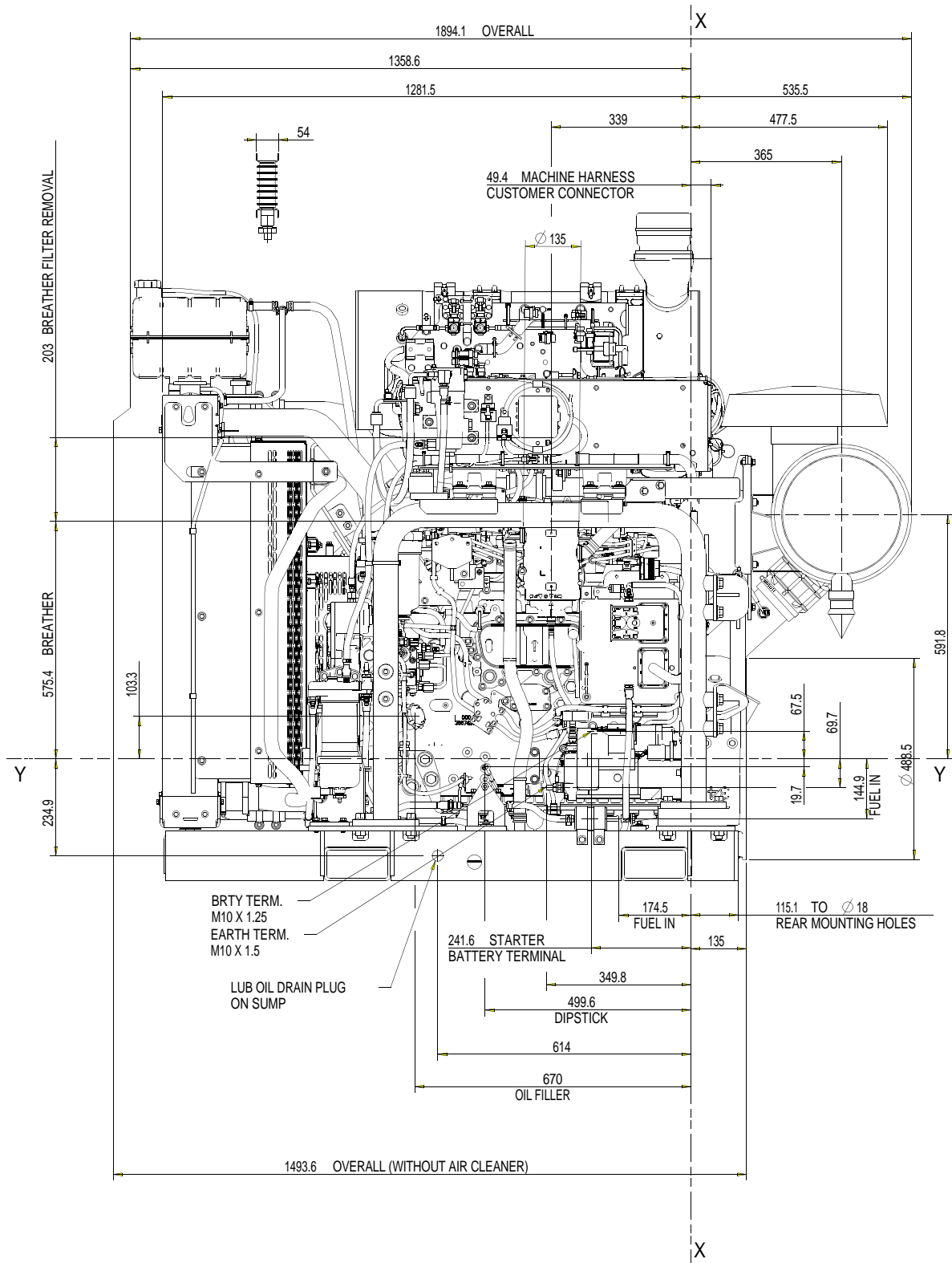

200 kWe @ 1800 rpm - front view

BL51550_GA / 06

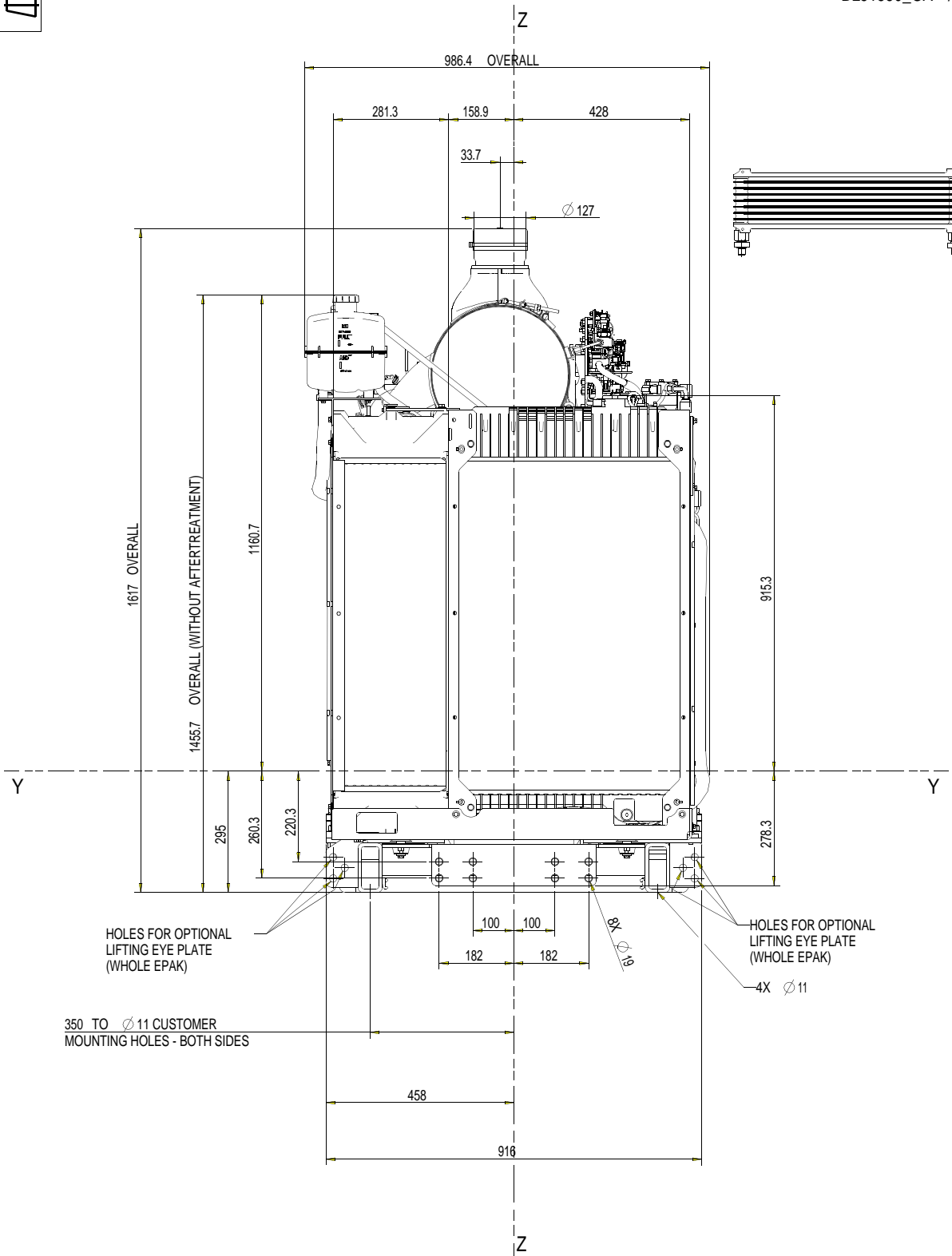

200 kWe @ 1800 rpm - right side view

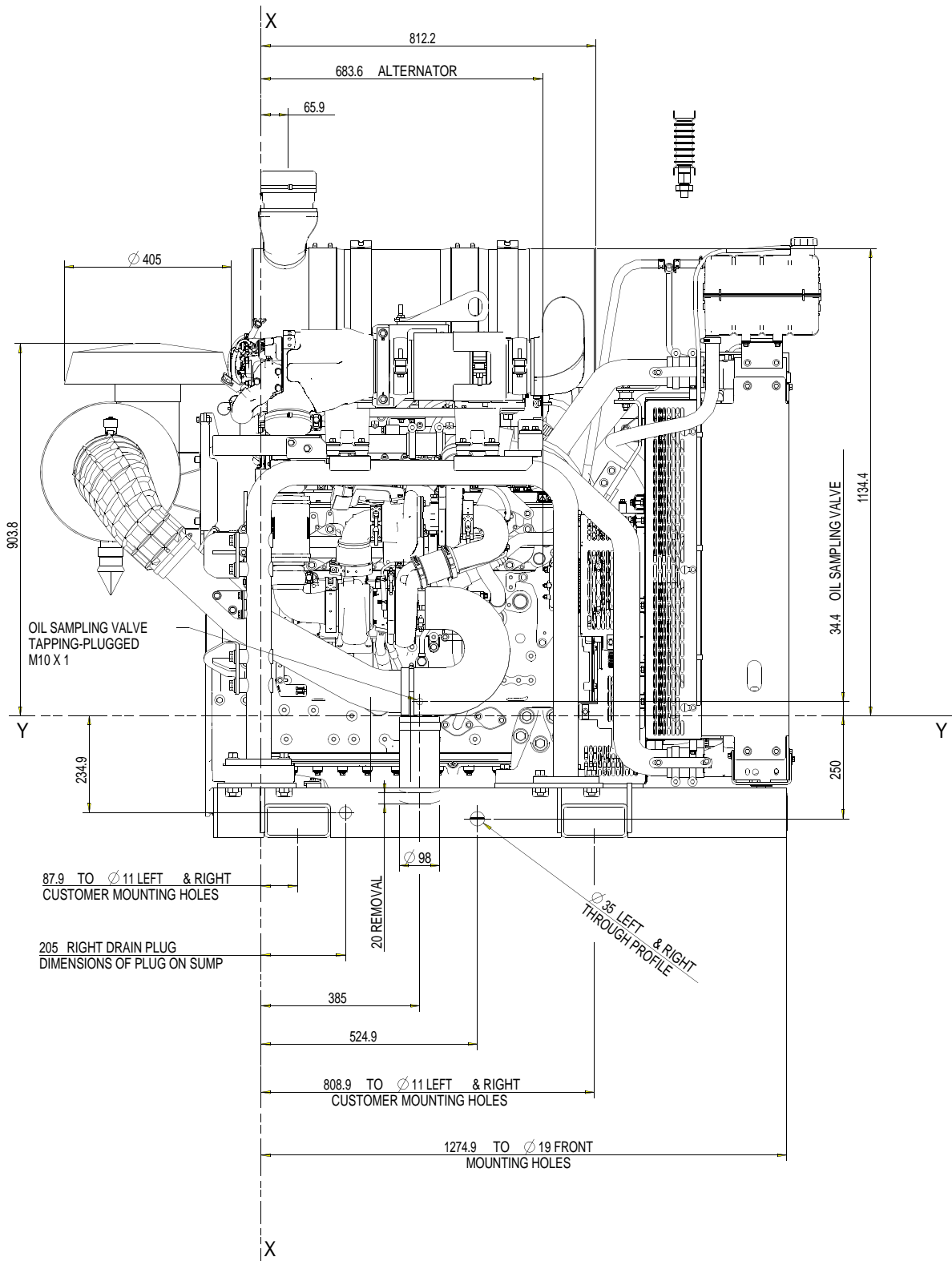

200 kWe @ 1800 rpm - rear view

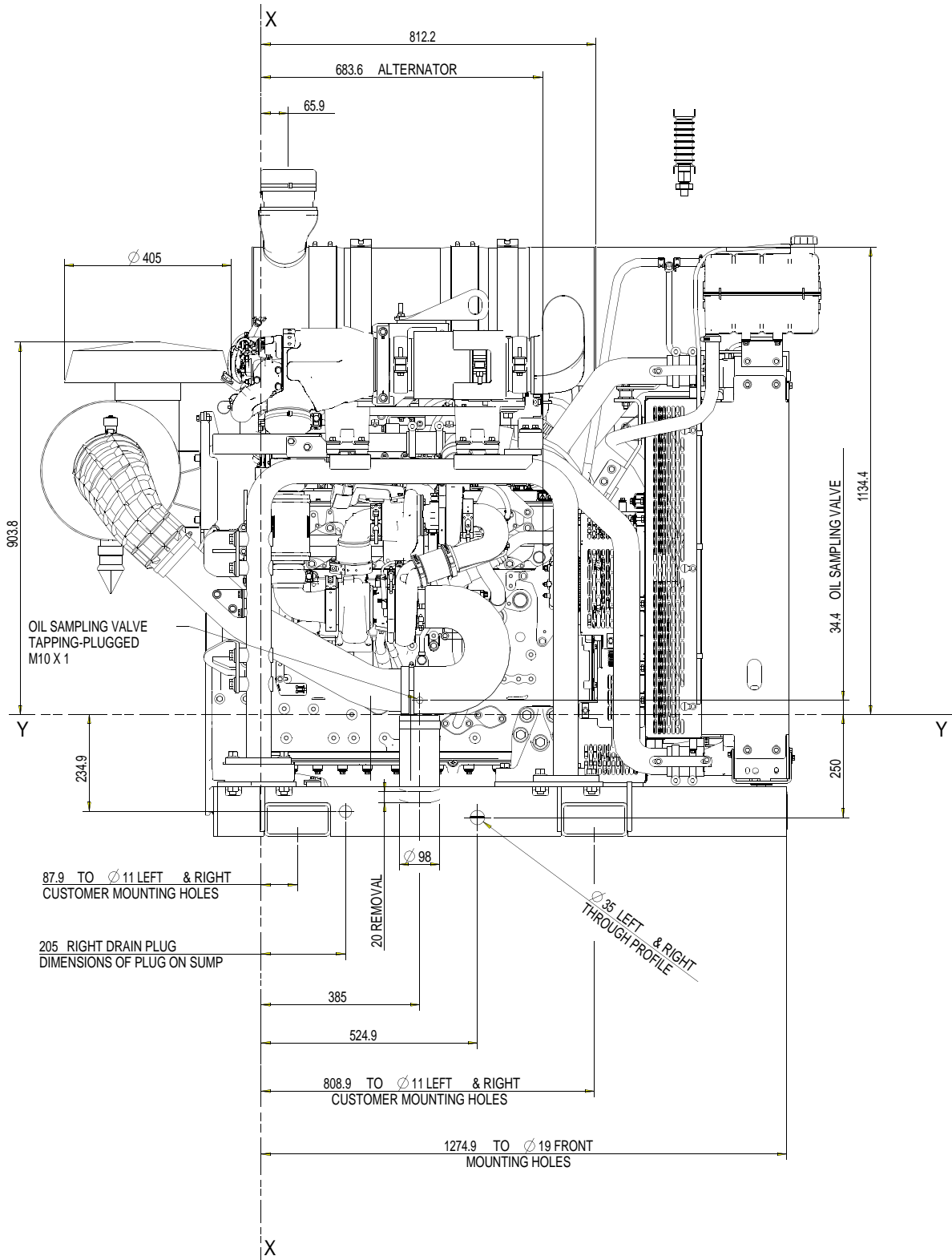

200 kWe @ 1800 rpm - plan view

BL51550_GA / 06

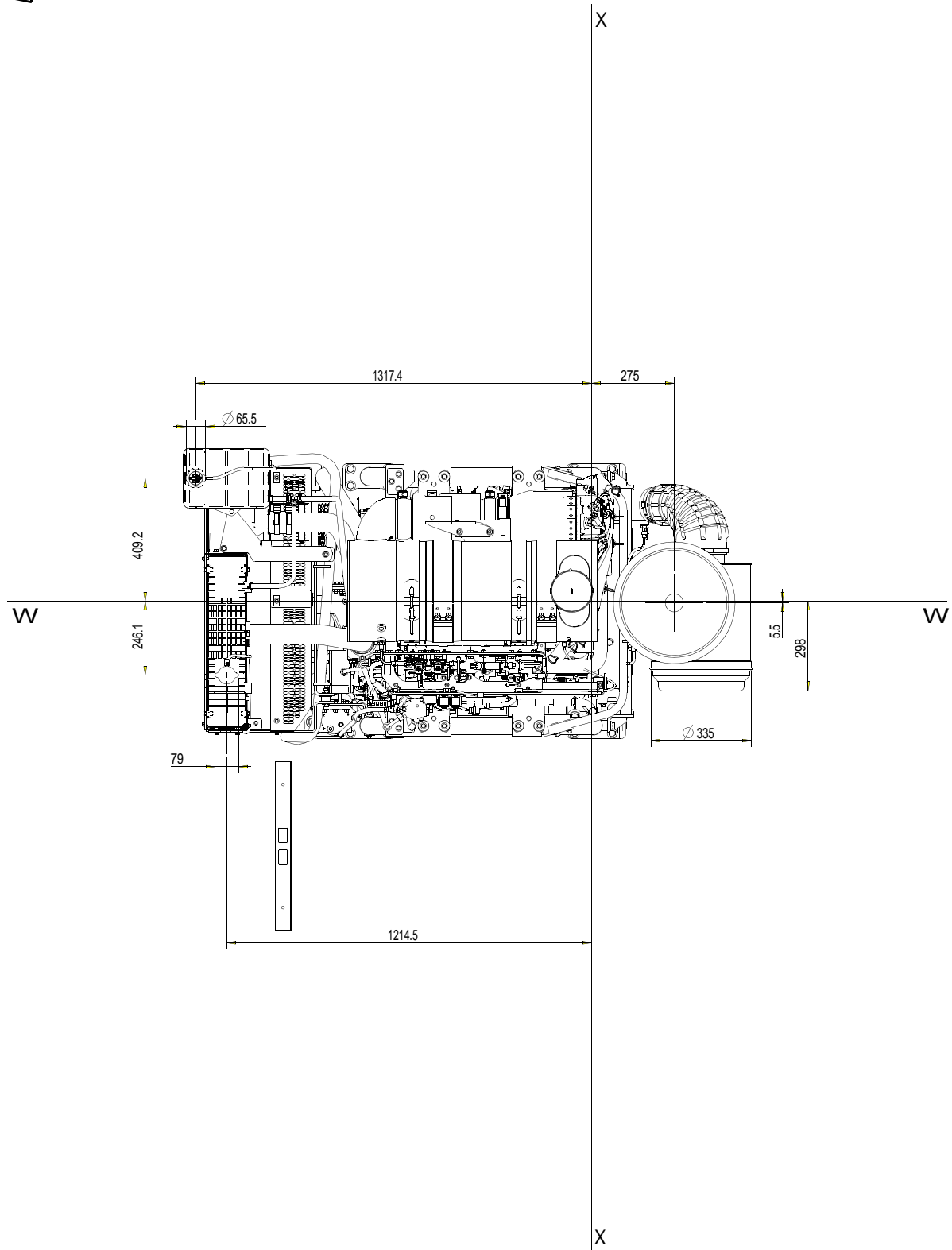

Cooling system

Cooling pack

Overall weight (wet) 101.7 kg
 Overall face area0.664640 m²
 Width875.8 mm
 Height1088.5 mm

Radiator

Max load on rad assembly from stone guard mounts..... 2.8 kg
 Face area0.444000 m²
 Number of rows57
 Matrix density and material.....10 fins/inch
 Width of matrix.....555.0 mm
 Height of matrix800.0 mm
 Pressure cap setting100.0 kPa

Charge cooler

Face area0.203404 m²
 Number of rows and materials.....2
 Matrix density and material.....13 fins/inch
 Width of matrix.....257.8 mm
 Height of matrix789.0 mm

Fan

TypePuller
 Diameter.....724 mm
 Drive ratio1:133
 Number of blades7
 Blade Material.....Composite
 Airflow at rated speed (1800 rpm) m³/sec
 Power absorbed @ 1800 rpm..... kW

Coolant

Total system capacity.....24.25 litres
 Bare engine capacity.....12.25 litres
 Maximum top tank temperature.....108°C
 Thermostat operation range82 - 94°C
 Temperature rise across engine (maximum).....°C
 Coolant pump driveGear
 Recommended coolant immersion heater rating (minimum)0.6 kW

Recommended coolant

BS6580 - 1992, and ELC coolants to 1E1966
 Maximum additional restriction (Duct allowance) to cooling airflow and resultant Min. airflow.

Puller

	Ambient clearance	Duct allowance	Cooling fan airflow	Radiator core resistance
Engine speed rpm	°C	Pa	m ³ /sec	kPa
1800	50	120	6.07	490
1800	48	200	5.62	430

Electrical system

Alternator	Unit	N0102	N0201
Alternator voltage	Volts	12	24
Alternator output	Amps	100	80

Starter	Unit	E0100	
Starter motor voltage	Volts	12	24
Starter motor power	kW	4.0	8.5
Number of teeth on flywheel	D0093	156	
	D0094	134	
	D0004	126	
Number of teeth on starter pinion		10	12
Minimum cranking speed	rpm	100	100
Starter solenoid - Max. pull-in current @ -20°C	Amps	68	2
Starter solenoid - Max. hold-in current @ -20°C	Amps	20	2

Engine stop method.....Electronic

Cold start recommendations

Minimum battery cold cranking amps

Air Temp./Oil viscosity limit	-5	-10	-15	-20	-25	Max battery CCA
With glow plugs 12v AZF & P5	15W40	15W40	15W40	10W40	5W30	
	950	950	1650	1650	1900	2400
No glow plugs 12V AZF	15W40	15W40	15W40	10W40	5W30	
	950	950	Must use G/plugs	Must use G/plugs	Must use G/plugs	2400
With glow plugs 24V IMT	15W40	15W40	15W40	10W40	5W30	
	525	525	680	680	750	1400
No glow plugs 24V IMT	15W40	15W40	15W40	10W40	5W30	
	525	525	Must use G/plugs	Must use G/plugs	Must use G/plugs	1400
With glow plugs 24V AZF HP	15W40	15W40	15W40	10W40	5W30	
	525	525	680	680	680	1200
No glow plugs 24VAZF HP	15W40	15W40	15W40	10W40	5W30	
	525	525	Must use G/plugs	Must use G/plugs	Must use G/plugs	1200

Notes:

- Glow plugs needed below -10°C.
- For cable sizes see Applications and Installation Manual.

Exhaust system aftertreatment SF451

Aftertreatment system type... DOC and DPF with ARD
 Type of regeneration ... High temperature
 Aftertreatment height ... 643.9 mm (25.4 Inch)
 Aftertreatment length ... 918.7 mm (63.2 Inch)
 Aftertreatment width ... 714.4 mm (28.1 Inch)
 Aftertreatment weight ... 134.0 Kg
 Outlet orientation when viewed from rear of engine ... 90°
 Aftertreatment skin temperature ... 250.0°C
 Max Temp for electronic components on aftertreatment ... 120.0°C
 Max Temp for external electronic components for Aftertreatment (soot sensor box) ... 85.0°C
 Typical maximum temperature exhaust out. ...
 . . Same as - exhaust gas temperature (Ex. manifold / turbo outlet)
 Maximum system back pressure limit... 35.0 kPa
 Aftertreatment exhaust outlet connection ... 127.0 mm
 Aftertreatment exhaust outlet connection load limit. ... 60.0 Nm
 Attenuation of the DPF ... 25.0 dB(A)
 Ash service... 5000.0 hours
 Maximum back pressure for customer installed pipe work.. 60 kPa

Induction system

Maximum air intake restriction
 Clean filter ... 5.0 kPa
 Dirty filter ... 8.0 kPa
 Induction indicator setting ... 8.0 kPa
 Air filter type. ... 125 pm

Fuel injection system

Fuel pump type / model ... HP4
 Injection system ... Electronic
 Injector type ... Common rail
 Injection pressure... 200 kPa

Fuel Priming

Priming pump type ... Gerotor
 Maximum priming time... seconds

Fuel feed

Maximum fuel supply restriction at primary filter... -30 kPa
 Maximum fuel return restriction at low idle ... 20 kPa
 Maximum fuel return flow... 2.5 l/min
 Maximum fuel flow through inlet connection. ... 3.7 l/min
 Maximum lift pump delivery rate ... 3.7 l/min
 Maximum lift pump delivery pressure ... 8500 kPa
 Maximum suction head at fuel pump inlet. ... 50 kPa
 Maximum static pressure head. ... 20 kPa
 Maximum fuel temperature at lift pump inlet. ... 80°C
 Maximum fuel filter service interval... 500 hrs

Fuel specification

ULSD (Ultra Low Sulphur Diesel) ... 15ppm Sulphur

Fuel consumption (SFC)

Load	g/kW.hr	litres/hr
25%		
50%		
75%		
100% (Prime)	216.0	
110% (Standby)		

1200 Series

200 kWe @ 1800 rpm

Lubrication system

Maximum system capacity (oil rail, oil filter, oil cooler) ... 1.9 Litres
 Maximum capacity in sump... ..16.0 Litres
 Minimum capacity in sump... ..13.0 Litres
 Maximum oil temperature continuous operation ... 125°C
 Maximum oil temperature intermittent operation.. ... 135°C

Lubricating oil pressure

At rated speed.. ...400 - 520 kPa
 Minimum220.0 kPa
 Oil relief valves opens at.. ... 520 kPa
 Sump drain plug tapping size
 or hose connection size3/4 UNF STOR port
 Oil pump drive method.. ... Gerotor (gear driven off crankshaft)
 Oil pump speed2 x engine speed
 Lubricating oil flow at rated speed60 litres/min.
 Oil consumption at full load rated speed 0.08 % of fuel

Recommended SAE viscosity

A multigrade oil conforming to API-CJ4, must be used.

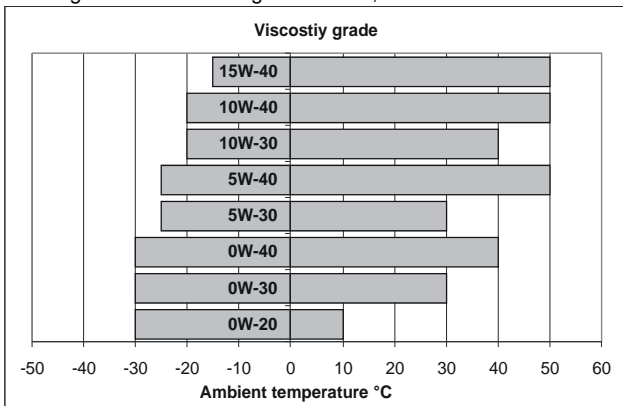

Normal operating angles

Front and rear25°
 Side.. ..25°

PTO capabilities

Flange type	SAE A
Torque capability intermittent	N/A
Torque capability continuous	N/A
Maximum bending moment at flange	N/A

Note: Refer to “Applications and Installation Manual” for “PTO approval requirements”.

Mountings

Maximum static bending moment at rear face of block	Nm	1130
Maximum permissible overhung load on the flywheel	kN	See Polar diagram Chapter 6 of the ESM

Bending moments (BM)

		Dynamic vertical BM	Dynamic lateral BM
Max. bending moment at rear of flywheel housing (Nm) - SAE 3	Nm	±3000	±1700
Max. bending moment at rear of flywheel housing (Nm) - SAE 2	Nm	±5600	±2800
Max. bending moment at rear of flywheel housing (Nm) - SAE 1	Nm	±8200	±5750

Note: Refer to “Applications and Installation Manual” for “Bending Moment approval requirements”.

Perkins Engines Company Limited
 Peterborough PE1 5NA United Kingdom
 Telephone +44 (0) 1733 583000
 Fax +44 (0) 1733 582240
 www.perkins.com

All information in the document is substantially correct at the time of printing but may be subsequently altered by the company.

Distributed by