

Technical Data

1100D Series

Electropak

1106D-E66TAG4

192,3 kWm @ 1800 rev/min

Basic technical data

Number of cylinders ... 6
 Cylinder arrangement ... In-Line
 Cycle ... 4 Strokes
 Induction system ... Turbocharged and Air Charge Cooled
 Combustion system... Direct Injection Diesel
 Compression ratio ... 16,2:1
 Bore... 105 mm (4.1 in)
 Stroke ... 127 mm (5.0 in)
 Cubic capacity ... 6,6 litres (402.8 in³)
 Direction of rotation ... Clockwise
 Firing order ... 1, 5, 3, 6, 2, 4

Estimated total weight

-dry ... 788 kg (1737 lb)
 -wet ... 822 kg (1812 lb)

Overall dimensions

-height ... 1140,4 mm (44.9 in)
 -length (air cleaner fitted) ... 1763,2 mm (69.4 in)
 -width ... 788,3 mm (31.0 in)

Moments of inertia

Engine rotational components ... 0,27 kgm²
 Flywheel ... 1,31 kgm²

Centre of gravity (wet)

Forward from rear of block ... 474,8 mm (18.7 in)
 Above crankshaft centre line... 177,3 mm (7.0 in)
 Offset to RHS of crankshaft centre line... 18,2 mm (0.7 in)

Performance

Note: All data based on operation to ISO 14396 and ISO 3046/1 standard reference conditions.

Speed variation at constant load ... ± 3%

Cyclic irregularity at 110% stand-by power

-1800 rev/min ... 0,020

Test conditions

-air temperature... 25 °C (77 °F)
 -barometric pressure ... 100 kPa (29.5 in hg)
 -relative humidity ... 31,5 %

Sound level

Average sound pressure level 100% Prime Power load for
 -Electropak at 1 metre ... TBA dB(A)
 All ratings certified to within ... ± 3%

If the engine is to operate in ambient conditions other than those of the test conditions, suitable adjustments must be made for these changes. For full details, contact Perkins Technical Service Department.

General installation

Designation	Units	Type of operation and application	
		Prime	Standby
		60Hz	
Gross engine power	kWb (bhp)	185,7 (249.0)	204,3 (274.0)
Brake mean effective pressure	kPa (lbf/in ²)	1877,0 (272.2)	2065,0 (299.5)
Mean piston speed	m/s (ft/s)	7,62 (25.0)	
Electropak net engine power	kWm (bhp)	173,7 (232.9)	192,3 (257.9)
Engine coolant flow (against 35 kPa restriction)	l/min (UK gal/min)	216,0 (57.1)	
Combustion air flow (at STP)	m ³ /min (ft ³ /min)	13,0 (459.1)	13,4 (473.2)
Exhaust gas flow (max)	m ³ /min (ft ³ /min)	34,1 (1204.2)	35,5 (1253.7)
Exhaust gas temperature (max) in manifold (after turbocharger)	°C (°F)	526,2 (979.2)	537,4 (999.3)
Net engine thermal efficiency	%	38,6	39,1
Typical genset electrical output (0.8pf 25 °C)	kWe	160,0	175,0
	kVA	200,0	219,0
Regenerative Power (estimated)	kW (bhp)	14,9 (20.0)	
Assumed alternator efficiency	%	92,1	91,0
Energy balance			
Power in fuel (fuel heat of combustion)	kWt (bhp)	480,8 (644.8)	522,7 (701.0)
	Btu/min	27367,0	29751,9
Power to cooling fan	kWm (bhp)	12,0 (16.1)	
	Btu/min	683,0	
Power to coolant and lubricating oil	kWt (bhp)	86,8 (116.4)	93,5 (125.4)
	Btu/min	4940,6	5322,0
Power to exhaust	kWt (bhp)	157,2 (210.8)	168,8 (226.4)
	Btu/min	8947,8	9608,0
Energy to charge coolers	kWt (bhp)	36,3 (48.7)	39,9 (53.5)
	Btu/min	2066,2	2271,1
Power to radiation	kWt (bhp)	14,9 (20.0)	16,2 (21.7)
	Btu/min	848,1	922,1

1106D-E66TAG4 - Left side view

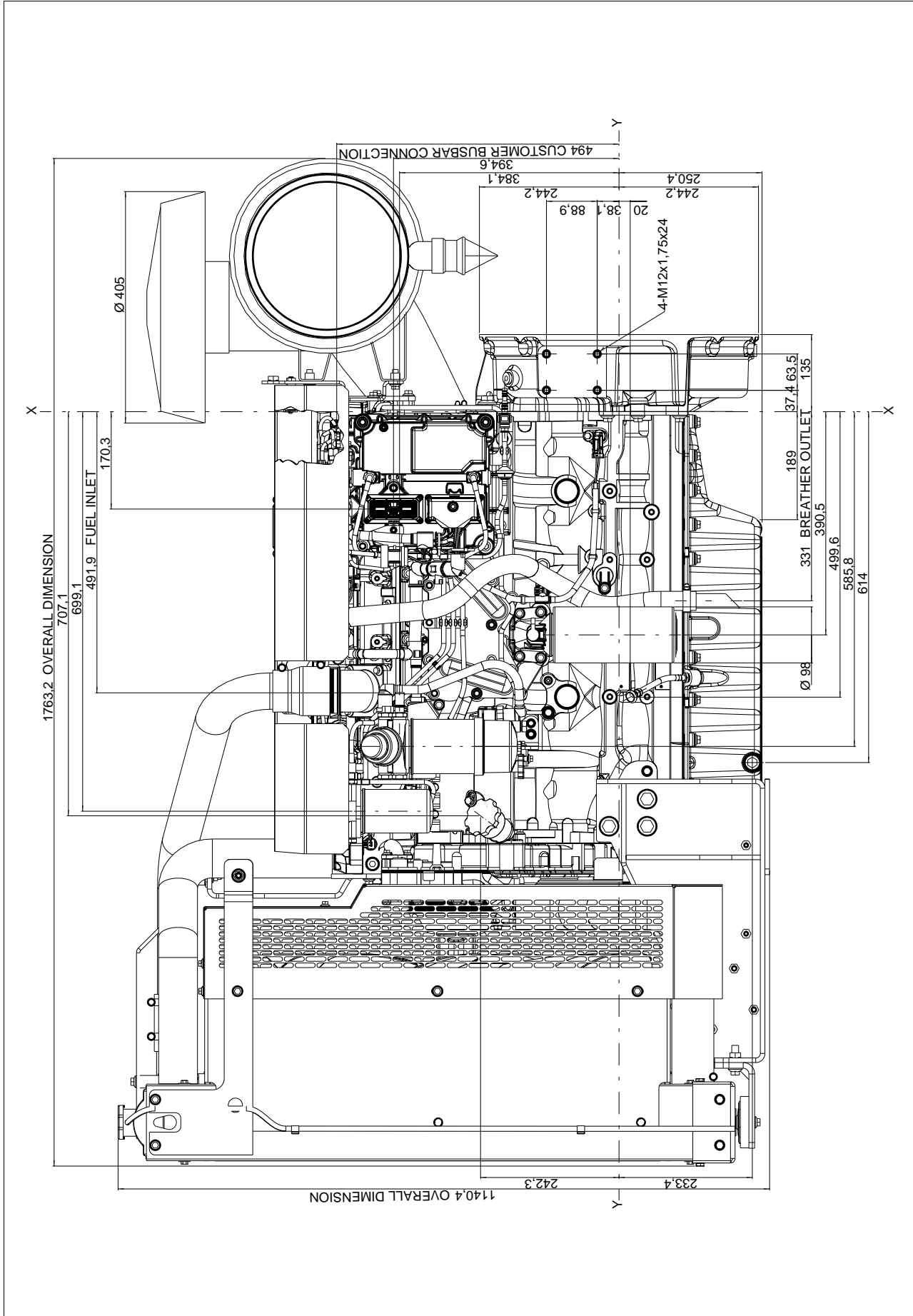

1106D-E66TAG4 - Front view

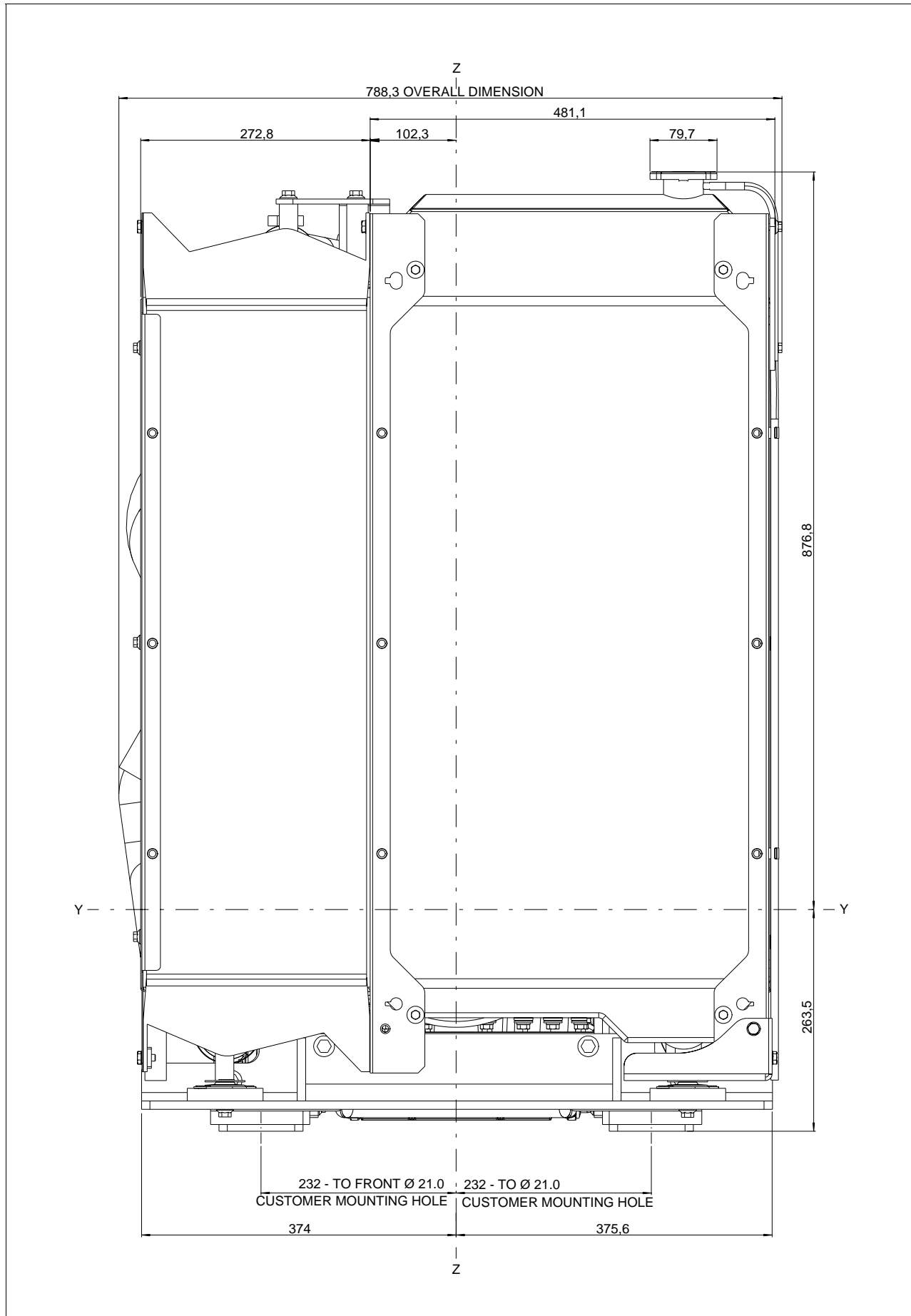

1106D-E66TAG4 - Right side view

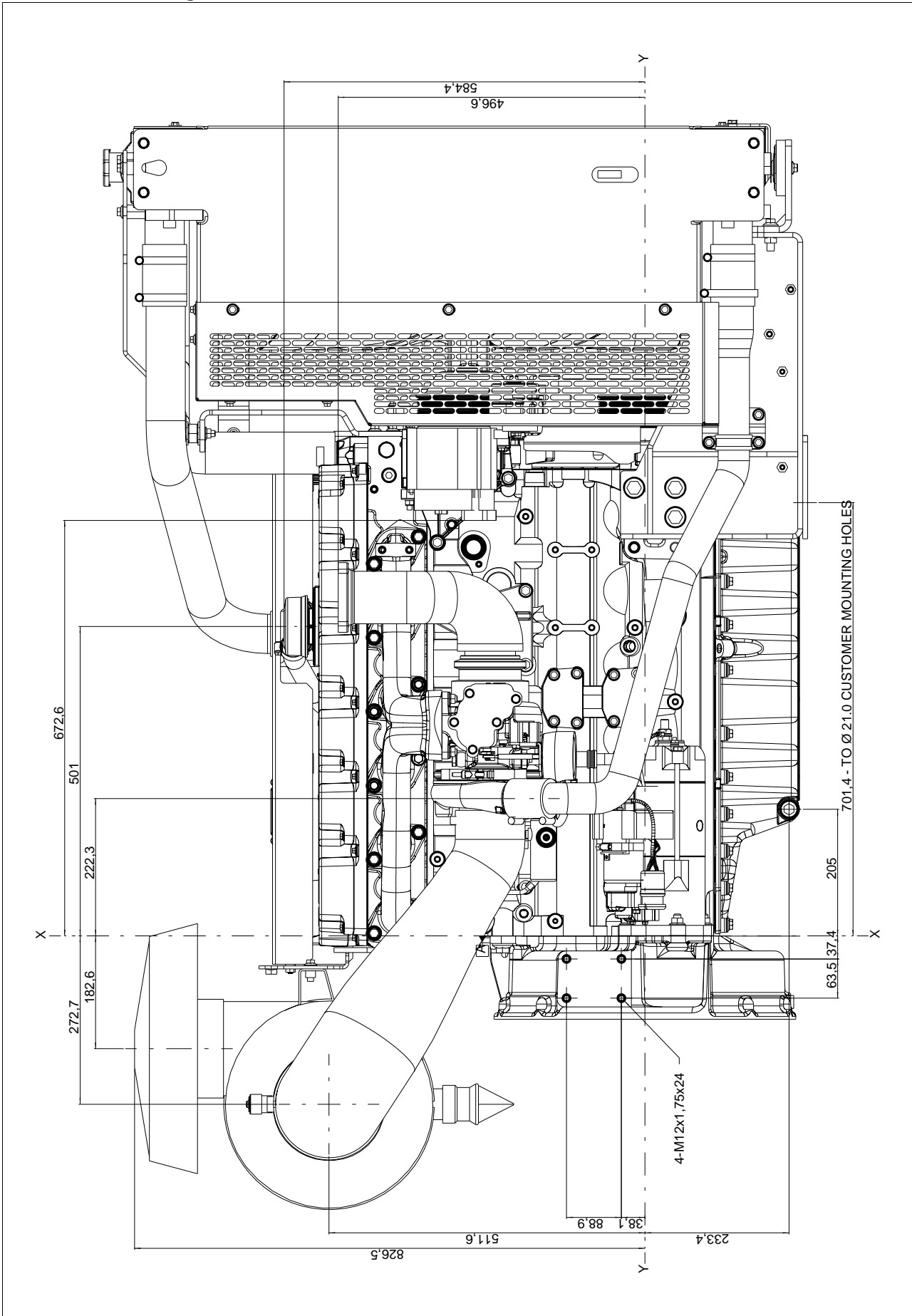

1106D-E66TAG4 - Rear view

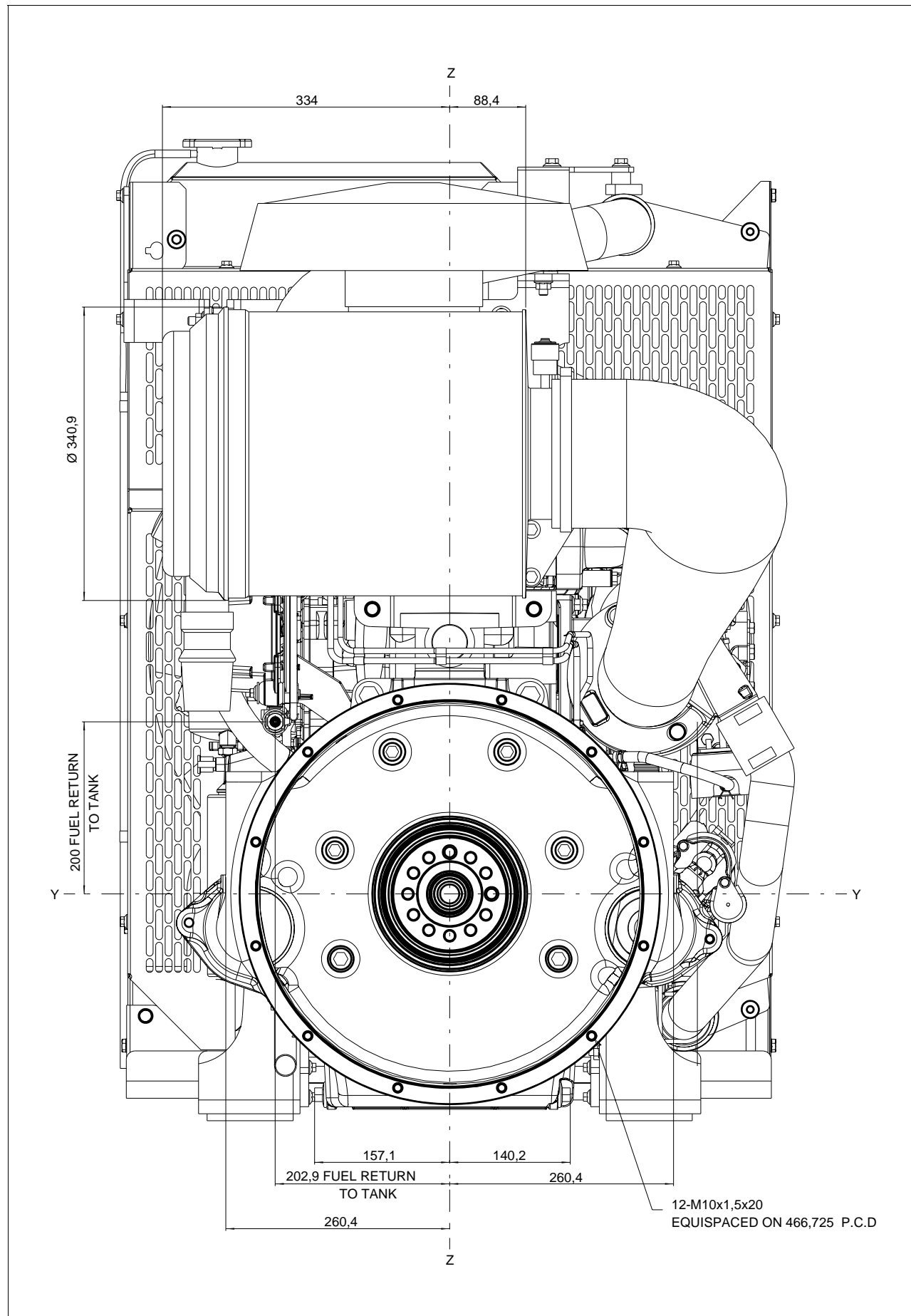

1106D-E66TAG4 - Plan view

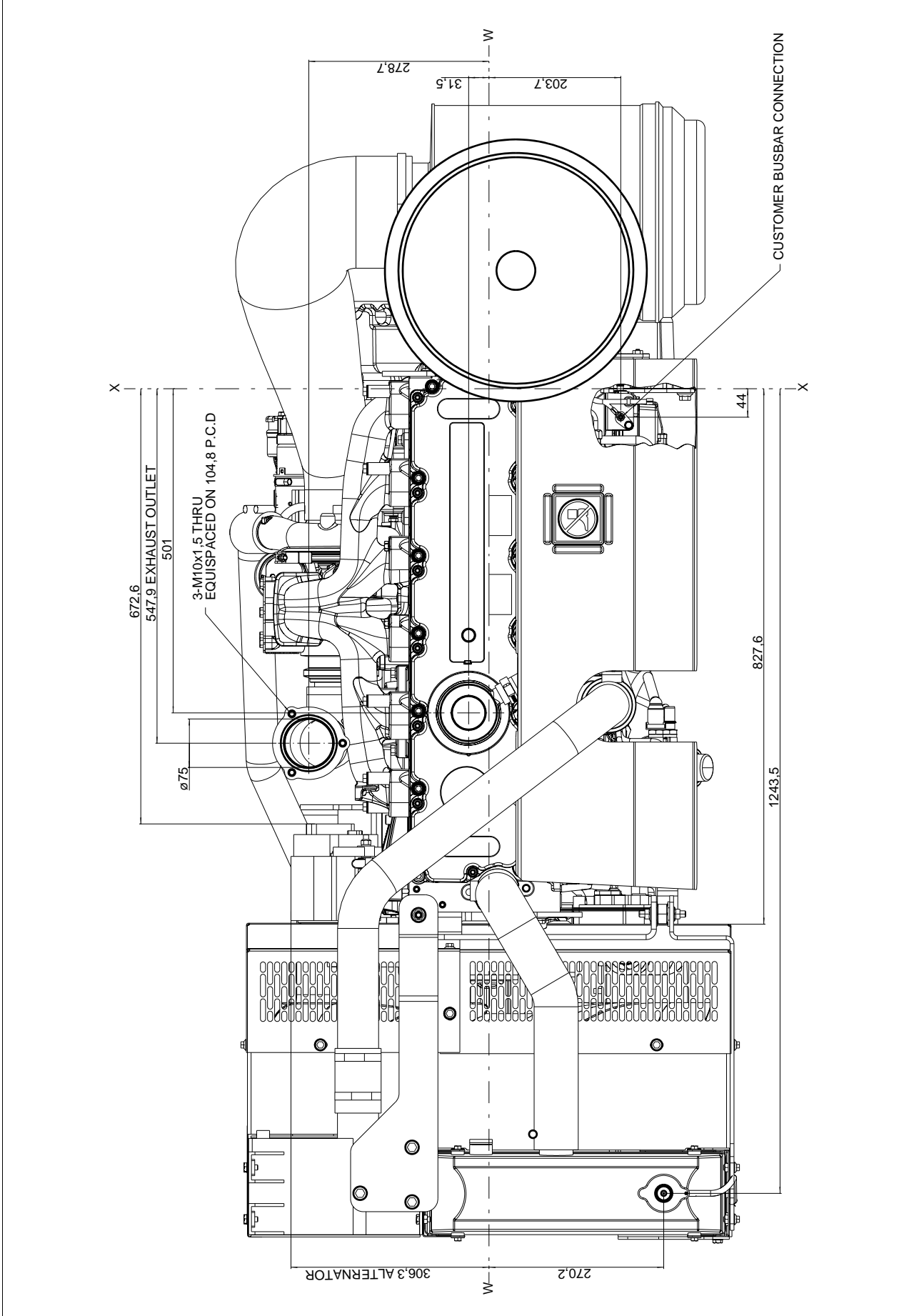

Cooling system

Cooling pack

-overall weight (wet) 71 kg
 -overall face area 554760 mm²
 -width 745 mm
 -height 1080 mm

Radiator

Face area 351200 mm²
 Number of rows and materials 5 rows, Aluminium
 Matrix density and material 10 fins per inch, Aluminium
 Width of matrix 439 mm (17.3 in)
 Height of matrix 800 mm (31.5 in)
 Pressure cap setting (min) 100 kPa (14.5 lb/in²)

Charge cooler

Face area 203560 mm²
 Number of rows and materials 2 rows, Aluminium
 Matrix density and material 10 fins per inch, Aluminium
 Width of matrix 258 mm
 Height of matrix 789 mm

Fan

Diameter 686 mm (27 in)
 Drive ratio..... 1,2:1
 Number of blades..... 7
 Material Nylon
 Type Pusher
 Air flow @ 1800 rev/min 313,8 m³/min

Coolant

Total system capacity 21 litres
 System drawdown capacity 10%
 Engine capacity 9,5 litres
 Maximum top tank temperature 112 °C (233.6 °F)
 Temperature rise across engine
 (max, rating dependent) 6,8 to 11,0 °C (44.2 to 51.8 °F)
 Max permissible external system resistance. 35 kPa (5.1 lbf/in²)
 Thermostat operation range..... 82 to 95 °C (179.6 to 203 °F)
 Shutdown switch setting 118 °C
 Coolant pump method of drive gears
 Coolant pump flow (against 35 kPa restriction). 215 litres/min

Recommended coolant immersion heater

rating (min) 0,75 kW
 Recommended coolant
 BS6580 - 1992, ASTM D3306 and ELC coolants to 1E1966

Electrical system

Alternator..... Denso A127i
 Alternator voltage 12 volts
 Alternator output 100 amps
 Starter 38MT
 Starter motor voltage 12 volts
 Starter motor power 5,0 kW
 Number of teeth on the flywheel 134
 Pull-in current of starter motor solenoid
 @ -25 °C max ⁽¹⁾ pulse signal 12 volts (5 amps)
 Hold-in current of starter motor solenoid
 @ -25 °C max ⁽¹⁾ pulse signal 12 volts (5 amps)
 Engine stop method via ECM

1 All leads to rated at 10 amps minimum

Cold start recommendations

Minimum required cranking speed over TDC 60 rev/min

Temperature Range	
5 to -10 °C	Oil: 15W40 Starter: 38MT Battery: 2x 900CCA Max breakaway current: 1012 Cranking current: 500 (760 max) Aids: Glowplugs Minimum mean cranking speed: 92 rev/min (at -15 °C)

Temperature Range	
-10 to -20 °C	Oil: 10W40 Starter: 38MT Battery: 2x 900CCA Max breakaway current: 1012 Cranking current: 500 (760 max) Aids: Glowplugs Minimum mean cranking speed: 103 rev/min

Temperature Range	
-20 to -25 °C	Oil: 5W40 Starter: 38MT Battery: 2x 900CCA Max breakaway current: 1012 Cranking current: 500 (760 max) Aid: Glowplugs Minimum mean cranking speed: 107 rev/min

- Battery capacity is defined by the 20 hour rate
- If a change to a low viscosity oil is made, the cranking torque necessary at low ambient temperatures is much reduced. The starting equipment has been selected to take advantage of this. It is important to change to the appropriate multigrade oil in anticipation of operating in low ambient temperatures
- Breakaway current is dependent on battery capacity available. Cables should be capable of handling the transient current which may be up to double the steady cranking current.

Exhaust system

Maximum back pressure @ 1800 rev/min 15,0 kPa (4.4 in Hg)
 Exhaust outlet, internal diameter 90 mm (3.5 in)

Fuel system

Injection components

Injector Electronic
 Fuel pump CR200

Fuel priming

Priming pump type Manual / Electronic
 Maximum priming time 90 seconds

Fuel feed

Maximum fuel flow 1,5 litres/min
 Maximum suction head at engine fuel pump inlet 30 kPa
 Maximum static pressure head 600 kPa
 Fuel temperature at engine fuel pump inlet 80 °C (176 °F)
 Tolerance on fuel consumption + 3%

Fuel specification

Fuel standard BS2869, 1998 Class A2 or BS EN590

Fuel consumption

Load		Type of Operation and Application	
		60Hz Prime	60Hz Standby
100%	g/kWhr (l/hr)	219,3 (48.5)	213,4 (51.9)
75%	g/kWhr (l/hr)	223,5 (37.1)	220,4 (40.2)
50%	g/kWhr (l/hr)	237,2 (26.2)	234,7 (28.5)
25%	g/kWhr (l/hr)	254,2 (14.0)	253,4 (15.4)

Induction system

Maximum air intake restriction

-clean filter 5 kPa (in H₂O)
 -dirty filter 8 kPa (in H₂O)
 -air filter type Paper Element

Lubrication system

Maximum total system oil capacity 16,5 litres (34.9 UK pints)
 Minimum oil capacity in sump 12,5 litres (26.4 UK pints)
 Maximum oil capacity in sump 15,5 litres (32.8 UK pints)
 Maximum engine operating angles - front up,
 front down, right side, left side 25 °
 Sump drain plug tapping size 3/4 - 16 UNF
 Shutdown switch setting (where fitted) TBA °C

Lubricating oil

-relief valve opening pressure 430 kPa (62.4 lbf/in²)
 -pressure at maximum speed 450 kPa (65.3 lbf/in²)
 -maximum continuous oil temperature (in rail) 125 °C
 -oil consumption at full load (% of fuel) < 0.1

Recommended SAE viscosity

A multigrade oil must be used which conforms to API-CH-4/C14.

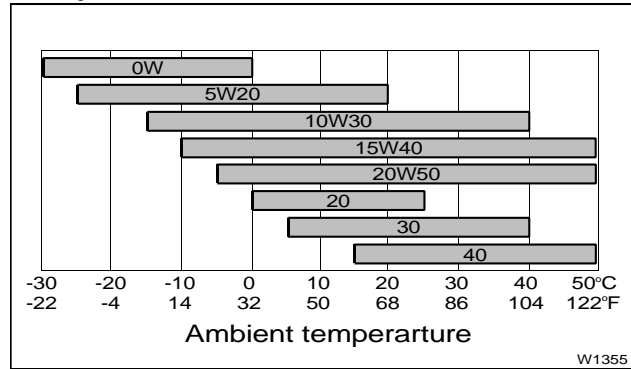

Mountings

Maximum static bending moment at
 -rear face of block 1130 Nm (833 lbf ft)
 Maximum permissible overhung load
 on the flywheel refer to the applications department
 Maximum bending moment (in shock)
 at rear face of flywheel housing:
 -vertical ± 4200 Nm
 -lateral ± 2800 Nm

Load acceptance (cold engine)

The below complies with the requirements of classification 3 and 4 of ISO 8528-12 and G2 operating limits stated in ISO 8528-5

Initial load application when engine reaches rated speed (15 seconds maximum after engine starts to crank)		
Descriptor	Units	1800 rev/min (60 Hz)
% of Prime Power	%	50
Load	kW (kWe)	93 (80)
Transient frequency deviation	%	≤ -10
Frequency recovery	seconds	5

The above figures were obtained under the following test conditions:
 -engine block temperature 15 °C
 -alternator 91%
 -minimum ambient temperature 10 °C
 -governing mode Isochronous
 -typical alternator inertia 1.948 kgm²

All tests were conducted using an engine which was installed and serviced to Perkins Engines Company Limited recommendations.

@ Perkins®

Perkins Engines Company Limited
 Peterborough PE1 5NA United Kingdom
 Telephone +44 (0) 1733 583000
 Fax +44 (0) 1733 582240
 www.perkins.com

Distributed by

All information in the document is substantially correct at the time of printing but may be subsequently altered by the company.