

# Technical Data

## 1100 Series

## 1104D-E44TAG2

### 111 kWm @ 1800 rev/min

## Diesel Engine Electropak

### Basic technical data

Number of cylinders ... 4  
 Cylinder arrangement ... vertical in-line  
 Cycle ... four stroke  
 Induction system ... turbocharged, air to air charge cooled  
 Compression ratio ... 16,2 : 1  
 Bore ... 105 mm  
 Stroke ... 127 mm  
 Cubic capacity ... 4,4 litres  
 Direction of rotation ... anti-clockwise when viewed from flywheel  
 Firing order ... 1, 3, 4, 2  
 Estimated total weight (fan to flywheel)  
 -dry ... 465 kg  
 -wet ... 474 kg

### Overall dimensions (Electropak)

-height ... 1086 mm  
 -length ... 1358 mm  
 -width (includes mounting brackets) ... 749 mm

### Moments of inertia (mk<sup>2</sup>)

-engine rotational components ... 0,124 kgm<sup>2</sup>  
 -flywheel ... 1,31 kgm<sup>2</sup>

### Centre of gravity (fan to flywheel)

-forward from rear of block ... 237,0 mm  
 -above centre line of block ... 167,0 mm  
 -offset to RHS of centre line ... -1,5 mm

### Performance

**Note:** All data based on operation to ISO/TR14396, BS5514, ISO3046/1 and DIN 6271 standard reference conditions.

-all ratings certified to within ... ±3%  
 Cyclic irregularity at rated power with 1,31 kgm<sup>2</sup> flywheel ... TBA

### Test conditions

-air temperature ... 25 °C  
 -barometric pressure ... 100 kPa  
 -relative humidity ... 30%  
 -air inlet restriction at rated speed ... 5 kPa  
 -exhaust back pressure at rated speed (nominal) ... 15 kPa

### Sound level

Estimated Electropak sound power level @ 1 metre without inlet and exhaust ... 105,5 dB(A)  
 If the engine is to operate in ambient conditions other than those of the test conditions, suitable adjustments must be made for these changes. For full details, contact Perkins Technical Service Department.

For details of load acceptance values, refer to page 8 of this publication.

**Emissions capability:** Certified against the requirements of Tier 3 legislation for non-road mobile machinery, powered by constant speed engines (EPA 40 CFR Part 89 Tier 3).

### General installation

Designation	Units	Prime	Standby
Gross engine power	kWb	106,0	117,0
Electropak nett engine power	kWm	100,0	111,0
Brake mean effective pressure	kPa	1612,0	1771,0
Engine coolant flow (against 35 kPa restriction)	l/min	169,0	169,0
Cooling fan air flow (200 kPa external restriction)	m <sup>3</sup> /min	224,4	224,4
Combustion air flow (at rated speed)	m <sup>3</sup> /min	8,4	8,5
Exhaust gas flow (max.)	m <sup>3</sup> /min	19,2	20,0
Exhaust gas mass flow (max.)	kg/min	10,2	10,3
Exhaust gas temperature in manifold Max.	°C	480,0	506,0
Boost pressure ratio	-	2,7	2,8
Overall thermal efficiency (nett)	%	36	37
Typical genset electrical output (0.8 pf 25 °C)	kWe	90,0	100,0
	kVA	113,0	125,0
Assumed alternator efficiency	%	90	
<b>Energy balance</b>			
Energy in fuel	kWt	276,0	301,0
Energy in power output (gross)	kWt	106,0	117,0
Energy to cooling fan	kWm	6,0	6,0
Energy in power output (nett)	kWm	100,0	111,0
Energy to exhaust	kWt	81,0	87,0
Energy to coolant and oil	kWt	57,0	61,0
Energy to radiation	kWt	15,0	18,0
Energy to charge cooler	kWt	17,0	18,0

1104D-E44TAG2 ElectropaK - left side view

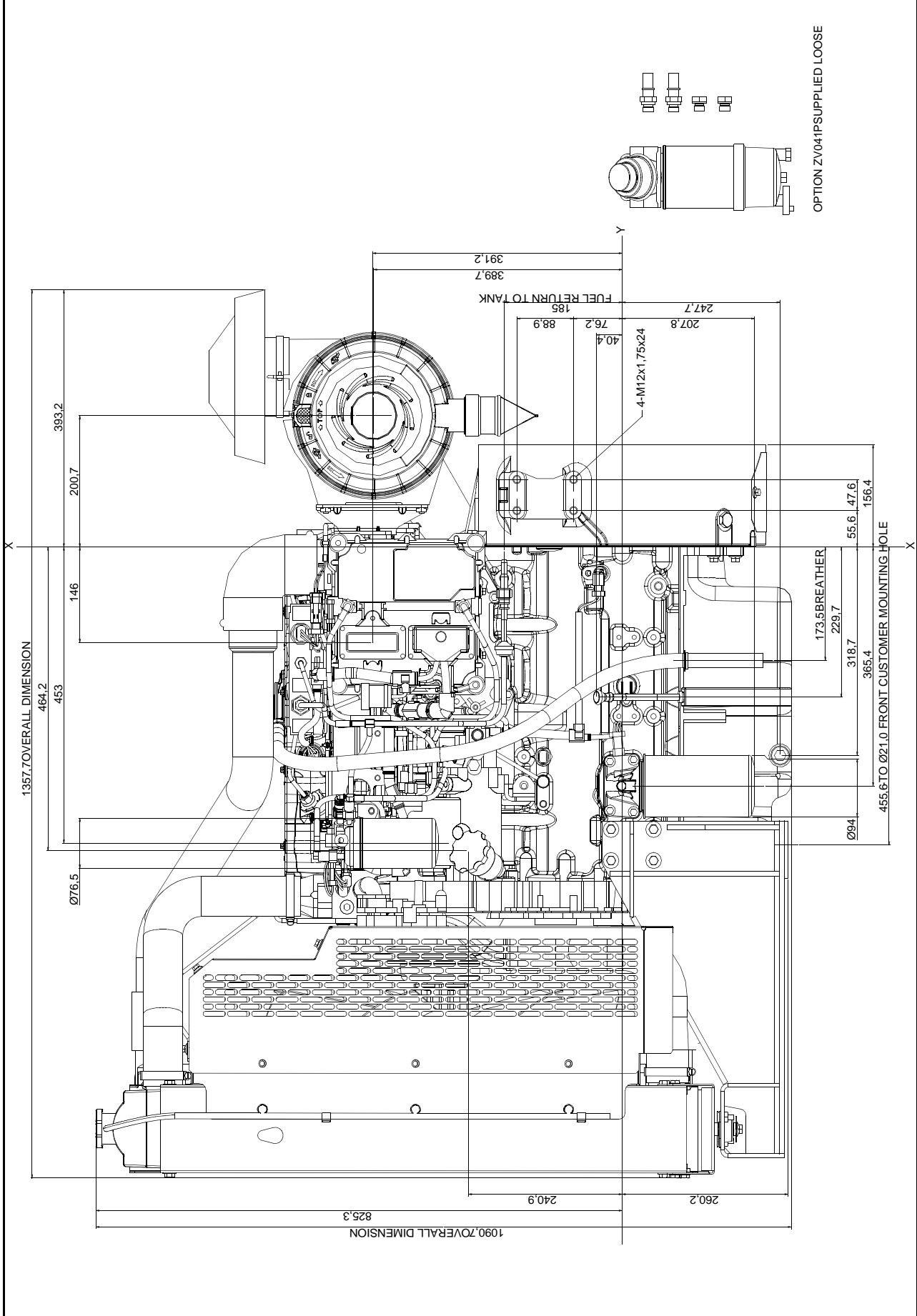

# 1104D-E44TAG2 ElectropaK - front view

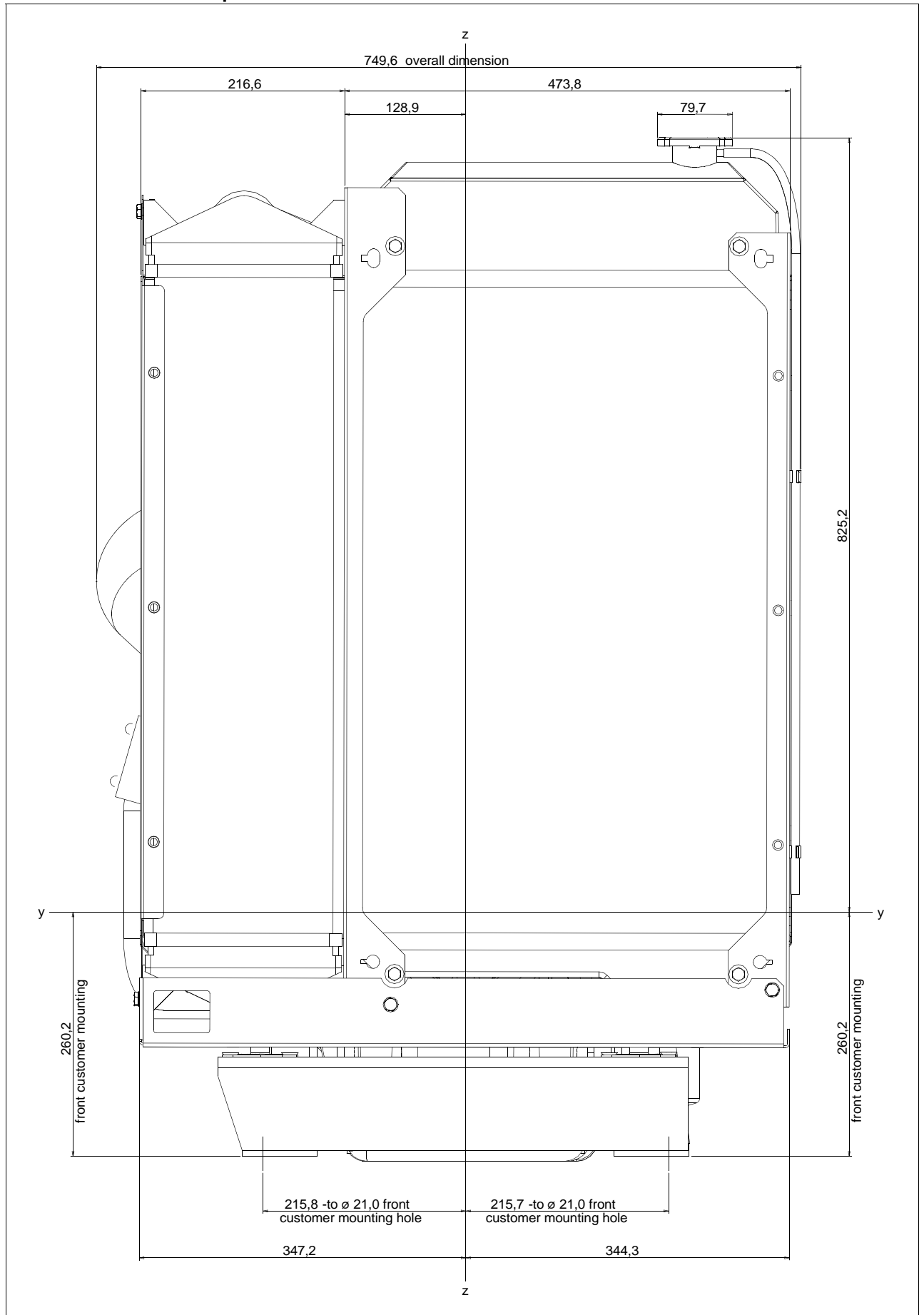

1104D-E44TAG2 ElectropaK - right side view

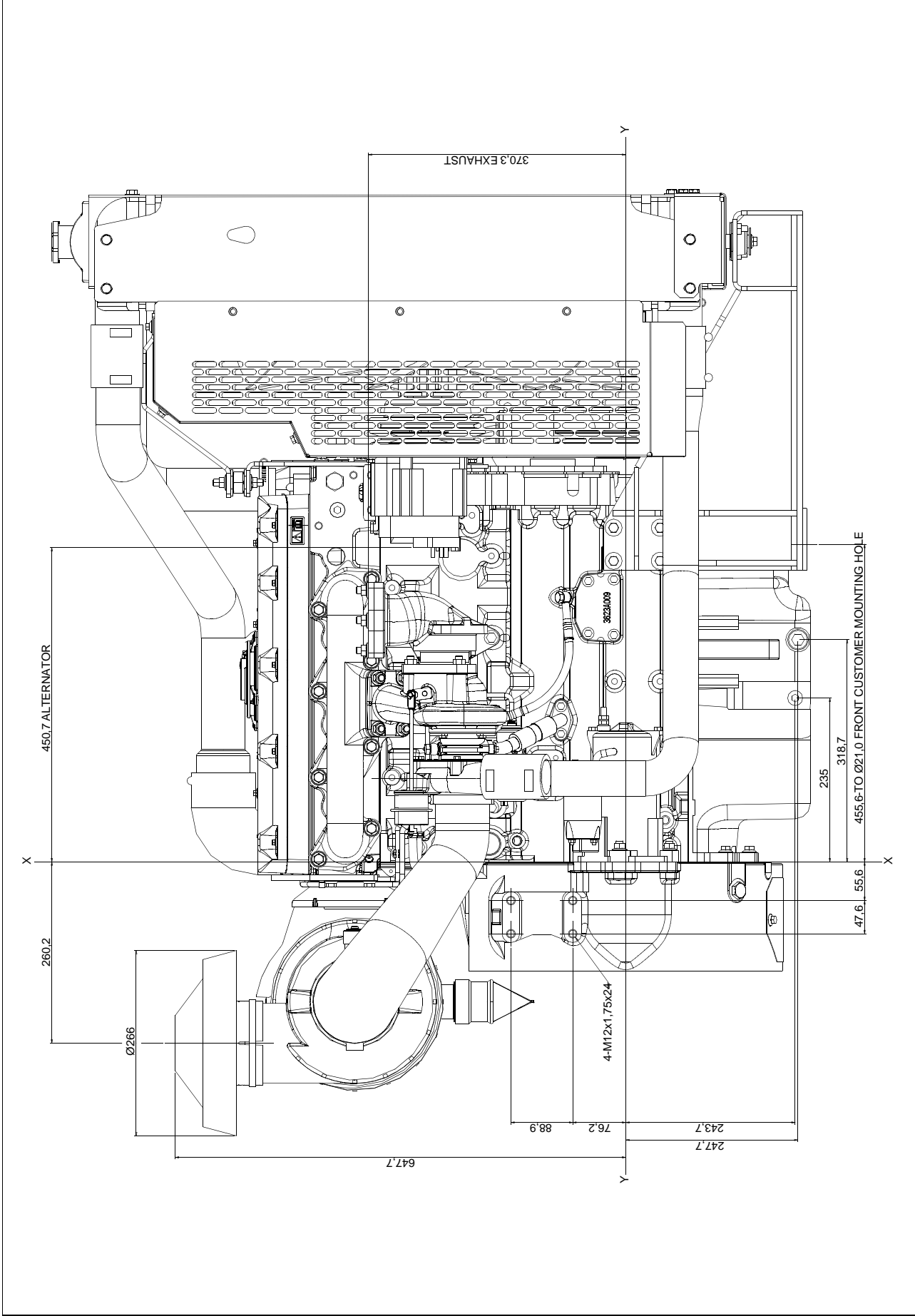

# 1104D-E44TAG2 Electropak - rear view

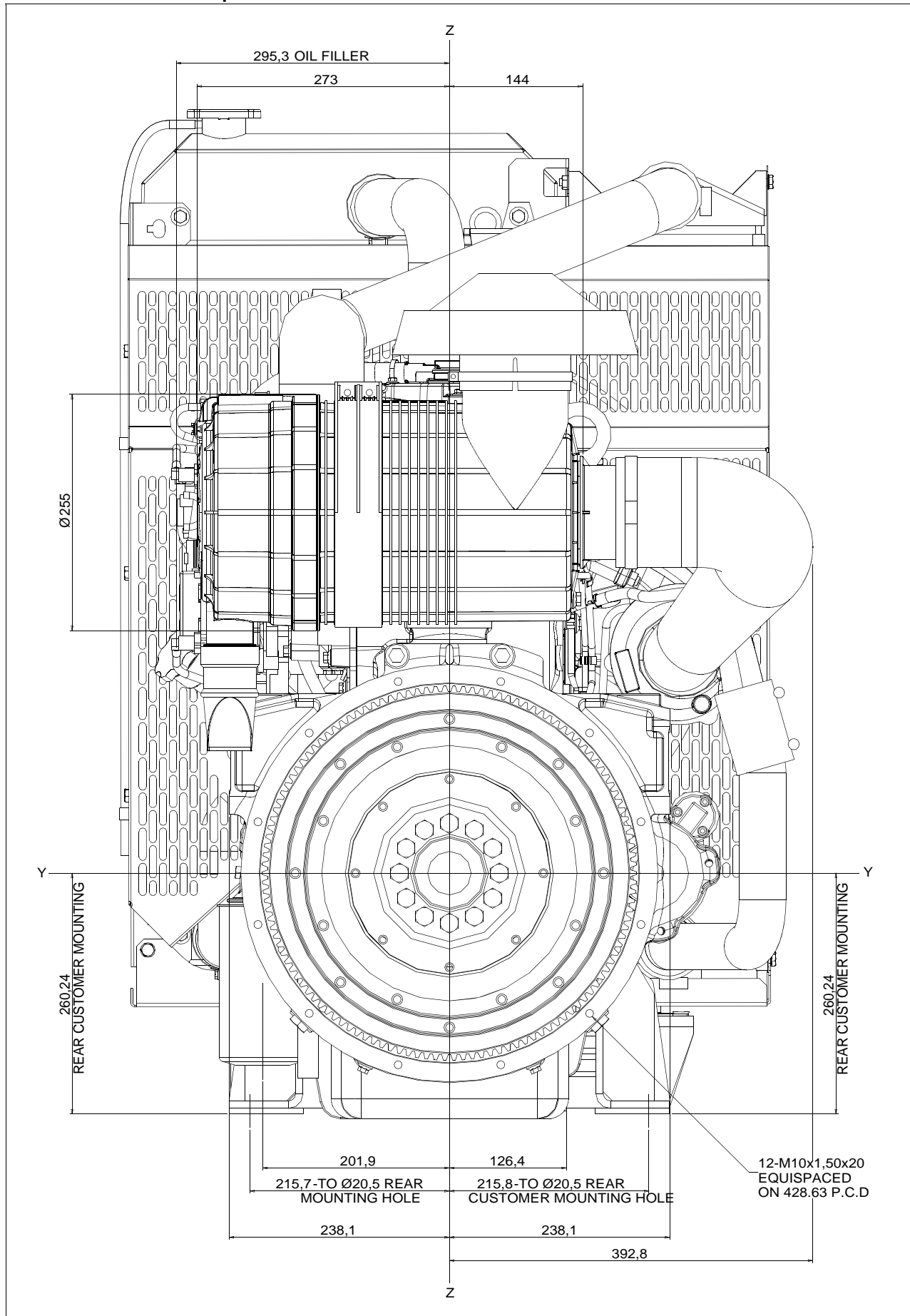

## Cooling system

### Cooling pack

overall weight (wet) .....	68,5 kg
overall face area of matrix .....	0,43 m <sup>2</sup>
width of matrix .....	629 mm
height of matrix .....	690 mm

### Radiator

-face area .....	0,3 m <sup>2</sup>
-number of rows and material .....	38 aluminium
-matrix density and material .....	10,0 aluminium fins per inch
-width of matrix .....	438 mm
-height of matrix .....	690 mm
-pressure cap setting .....	100 kPa

### Charge cooler

-face area .....	0,13 m <sup>2</sup>
-number of rows and material .....	9 aluminium
-matrix density and material .....	7,5 aluminium fins per inch
-width of matrix .....	191 mm
-height of matrix .....	690 mm

### Fan

-diameter .....	559 mm
-drive ratio .....	1,25:1
-number of blades .....	7
-material .....	composite
-type .....	pusher

### Coolant

Total system capacity	
-with radiator .....	17 litres
-without radiator .....	7,0 litres
Coolant pump drive .....	gear
Coolant pump drive ratio .....	2:1
Maximum top tank temperature .....	112 °C
Temperature rise across engine (rating dependent) .....	6,6 - 7,0 °C
Thermostat operation range .....	85 - 95 °C
Recommended coolant: 50% ethylene glycol with a corrosion inhibitor (BS 658 :1992 or MOD AL39) and 50% clean fresh water.	

Duct allowance with 50% glycol		
°C	kPa	m <sup>3</sup> /min
53	120	182
46	200	154

## Electrical system

-type .....	12 Volt negative earth
-alternator type .....	Denso A115i
-alternator voltage .....	12V
-alternator output .....	65A
-starter motor type .....	Denso P95
starter motor voltage .....	12V
-starter motor power .....	3,0 kW
-number of teeth on flywheel .....	115
-number of teeth on starter pinion .....	10
-minimum cranking speed .....	80 rev/min
-starter solenoid maximum pull-in current @ 0°C .....	TBA
-starter solenoid maximum hold-in current @ 0°C .....	TBA

## Cold start recommendations

Temp °C	Battery type and viscosity used					Starter aid	Min average cranking speed	Battery quantity
	20W	15W	10W	5W	0W			
-5		B				None	130	1
-10		D		A		None	130	2
-15			B			Gp	100	2
-15				A		Gp	100	2
-20			B			Gp	100	2
-20				B		Gp	100	2
-25						Gp	100	2

Note: Gp = Glowplugs

## Battery selection

Battery type	Perkins code	Battery minimum performance		
		Cold cranking current (Amps)		
		BS 3911 <sup>(1)</sup>	SAE J537 <sup>(2)</sup>	DIN 43539 <sup>(3)</sup>
643	A	440	660	400
647	B	510	770	465
069	D	340	540	300
655	E	570	810	490

1. Voltage no less than 7,5 volts after 10 seconds after 90 seconds at -18 °C across each 12 volt battery
2. Voltage no less than 7,2 volts after 30 seconds at -18 °C across 12 volt battery
3. Voltage no less than 6 volts after 150 seconds at -18 °C across 12 volt battery

### Notes:

- Battery to starter lead resistance must not be more than 0,0017 Ohms (12V system)
- Battery capacity is defined by the 20 hour rate
- If a change to a low viscosity engine oil is made, the required cranking torque at low ambient temperature is much reduced. The starting equipment has been selected to take advantage of this. It is important to change to the appropriate multigrade oil in anticipation of operating in low ambient temperature
- Breakaway current is dependent on the battery capacity. Cables should be capable of handling the transient current which may be double the steady cranking current

## Exhaust system

Maximum back pressure .....	15 kPa
Exhaust outlet size .....	64 mm

## Induction system

### Maximum air intake restriction

-clean filter .....	5 kPa
-dirty filter .....	8 kPa
-air filter type .....	2 stage cyclonic/paper element

## Fuel system

Type of injection ... direct  
 Fuel injection pump ... common rail  
 Fuel atomiser ... unit injector / multi-hole  
 Nozzle opening pressure ... 18,5 MPa

### Fuel lift pump

-max flow through customer filter... 130 litres/hour  
 -max fuel supply restriction at lift pump... 40 kPa  
 -max fuel return restriction @ low idle... 50 kPa  
 -max fuel return flow... 0,8 m³/min  
 Maximum suction head... 17 kPa (1.7 m)  
 Maximum static pressure head... 10 kPa (1.0 m)  
 Governor type... control by ECM  
 Speed control to... ISO 8528, G3

### Fuel specification

USA Fed Off Highway EPA2D 89.330-96  
 Density (kg/l @ 15°C) ... 0,845 - 0,855  
 Viscosity (mm²/s @ 40 °C) ... 2,0 - 3,2  
 Sulphur Content ... 0.03 - 0,04  
 Cetane Number... 40 - 48

### Fuel consumption litres/hour

Power Rating			
110%	100%	75%	50%
29,96	27,77	22,04	16,07

## Lubrication system

Lubricating oil capacity total system... 8,0 litres  
 Maximum sump capacity... 7,0 litres  
 Minimum sump capacity... 5,5 litres  
 Maximum engine operating angles  
 -front up, front down, right side or left side ... 25°

### Lubricating oil pressure

-relief valve opens... 450 kPa  
 -at maximum no-load speed... 280 - 340 kPa  
 -oil temperature (continuous operation) ... 125 °C  
 -oil temperature (maximum intermittent operation) ... 135 °C  
 Oil consumption at full load as a % of fuel consumption... 0.15%

### Recommended SAE viscosity

A single or multigrade oil must be used which conforms to API-CC/SE or CCMC-D1, see illustration below:

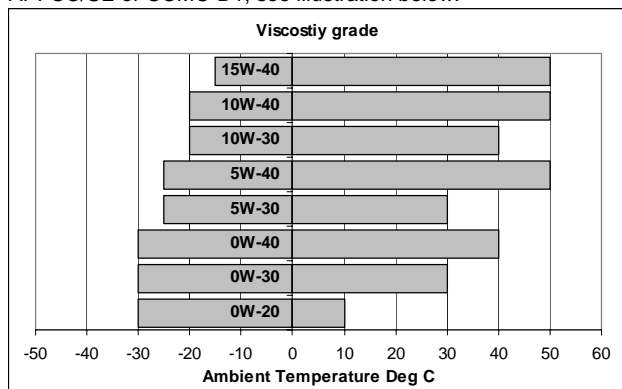

## Mountings

Maximum static bending moment at rear face of block ... 791 Nm

## Load acceptance

Initial load application when engine reaches rated speed, 15 seconds (maximum) after engine starts top crank		
Prime Power %	Transient frequency deviation %	Frequency recovery time seconds
80	10	1,44

### Notes:

- The above complies with the requirements of classifications 3 and 4 of ISO 8528-12 and G2 operating limits stated in ISO 8528-5
- The above figures were obtained under test conditions as follows:  
 Minimum engine block temperature ... 45 °C  
 Alternator efficiency ... 90%  
 Ambient temperature... 15 °C  
 Governing mode... Isochronous  
 Mechanical governing ... 4% ± 1%  
 Alternator inertia ... 8 kgm²  
 Flywheel inertia ... 1.14 kgm²  
 Under frequency roll off point (UFRO) set to... 1Hz below rated  
 UFRO rate set to ... 2% voltage / 1% frequency  
 LAM on/off ... off

All tests were conducted using an engine which was installed and serviced to Perkins Engines Company Limited recommendations.

@ Perkins®

Perkins Engines Company Limited  
Peterborough PE1 5NA United Kingdom  
Telephone +44 (0) 1733 583000  
Fax +44 (0) 1733 582240  
[www.perkins.com](http://www.perkins.com)

All information in the document is substantially correct at the time of printing but may be subsequently altered by the company.

Distributed by

