

# Technical Data

## 1100 Series

## 1103C-33 G2

Diesel engine - Electropak

**30,4 kWm @ 1500 rev/min**

**34,0 kWm @ 1800 rev/min**

### Basic technical data

Number of cylinders	3
Cylinder arrangement	Vertical in-line
Cycle	Four stroke
Induction system	Naturally Aspirated
Compression ratio	19,25 : 1
Bore	105 mm
Stroke	127 mm
Cubic capacity	3,3 litres
Direction of rotation	Anti-clockwise when viewed from flywheel
Firing order	1, 2, 3

### Estimated total weight (fan to flywheel)

-dry	329 kg
-wet	TBA kg

### Overall dimensions (electropak)

-height	951 mm
-length	1045 mm
-width (includes mounting brackets)	631 mm

### Moments of inertia (mk<sup>2</sup>)

Engine:	
-longitudinal	23,3 kgm <sup>2</sup>
-horizontal	38,1 kgm <sup>2</sup>
-axial	24,4 kgm <sup>2</sup>
Flywheel (polar)	1,14 kgm <sup>2</sup>

### Centre of gravity of engine (fan to flywheel)

-forward from rear of block	192,9 mm
-above centre line of block	139,0 mm
-offset to RHS of centre line	-4,7 mm

### Performance

**Note:** All data based on operation to ISO/TR14396, ISO3046/1 standard reference conditions.

Speed variation at constant load ... ± 0,5%

### Cyclic irregularity (for engine and flywheel)

Prime power:	
-at 1500 rev/min	± 0,5%
-at 1800 rev/min	± 0,5%

### Test conditions

-air temperature	25 °C
-barometric pressure	100 kPa
-relative humidity	30%
-air inlet restriction at maximum power	2 kPa
-exhaust back pressure	12 kPa
-fuel temperature (pump inlet)	40 °C

### Sound level

Estimated sound power level for bare engine without inlet and exhaust at 1 metre:

- @ 1500 rev/min	99 dB(A)
- @ 1800 rev/min	101 dB(A)
-all ratings certified to within	± 5%

If the engine is to operate in ambient conditions other than those of the test conditions, suitable adjustments must be made for these changes. For full details, contact Perkins Technical Service Department.

**Emissions capability:** Certified against the requirements of EU2007 (EU 97/68/EC Stage II) and EPA Tier 2 (EPA 40 CFR Part 89 Tier 2) legislation for non-road mobile machinery, powered by constant speed engines

## General installation

Designation	Units	Type of operation and application			
		Prime	Standby	Prime	Standby
		1500 rev/min		1800 rev/min	
Gross engine power	kWb	27,9	31,0	31,5	35,0
Fan power	kWm	0,6		1,1	
Brake mean effective pressure (gross)	kPa	1023	1128	1020	1124
ElectropaK nett engine power	kWm	27,3	30,4	30,5	34,0
Engine coolant flow 35 kPa system restriction	l/min	125,0		151,0	
Combustion air flow (at STP)	m <sup>3</sup> /min	2,16	2,13	2,60	
Exhaust gas flow (max)	m <sup>3</sup> /min	5,49	5,25	6,10	6,52
Exhaust gas outlet temperature (max. at standby)	°C	515,0	570,0	530,0	580,0
Nett engine thermal efficiency	%	36,2	36,6	36,3	36,6
Typical GenSet electrical output (0.8pf 25 °C)	kWe	25	27	27	31
	kVA	31	34	34	38
Friction power and pumping loss	kW	7,7		10,3	
Assumed alternator efficiency	%	90		90	
Cooling fan air flow (200 kPa external restriction)	m <sup>3</sup> /min	45,6		69,6	
Specific fuel consumption	l/min	0,13	0,15	0,20	0,21
<b>Energy balance</b>					
Power in fuel (fuel heat of combustion)	kWt	77,7	82,7	86,9	97,2
Power output (gross)	kWb	27,9	31,0	31,5	35,0
Power output (nett)	kWm	27,3	30,4	30,5	34,0
Power to cooling fan	kWm	0,6		1,1	
Power to coolant and lubricating oil	kWt	18,5	20,3	20,8	22,9
Power to exhaust	kWt	25,9	25,4	29,5	32,5
Power to radiation	kWt	5,4	5,9	6,1	6,7

**Caution:** The airflows shown in this table will provide acceptable cooling for an open power unit operating in ambient temperatures of up to 53 °C or 46 °C . if a canopy is fitted. If the power unit is to be enclosed totally, a cooling test should be done to check that the engine cooling is acceptable. If there is insufficient cooling, contact Perkins Technical Service Department.

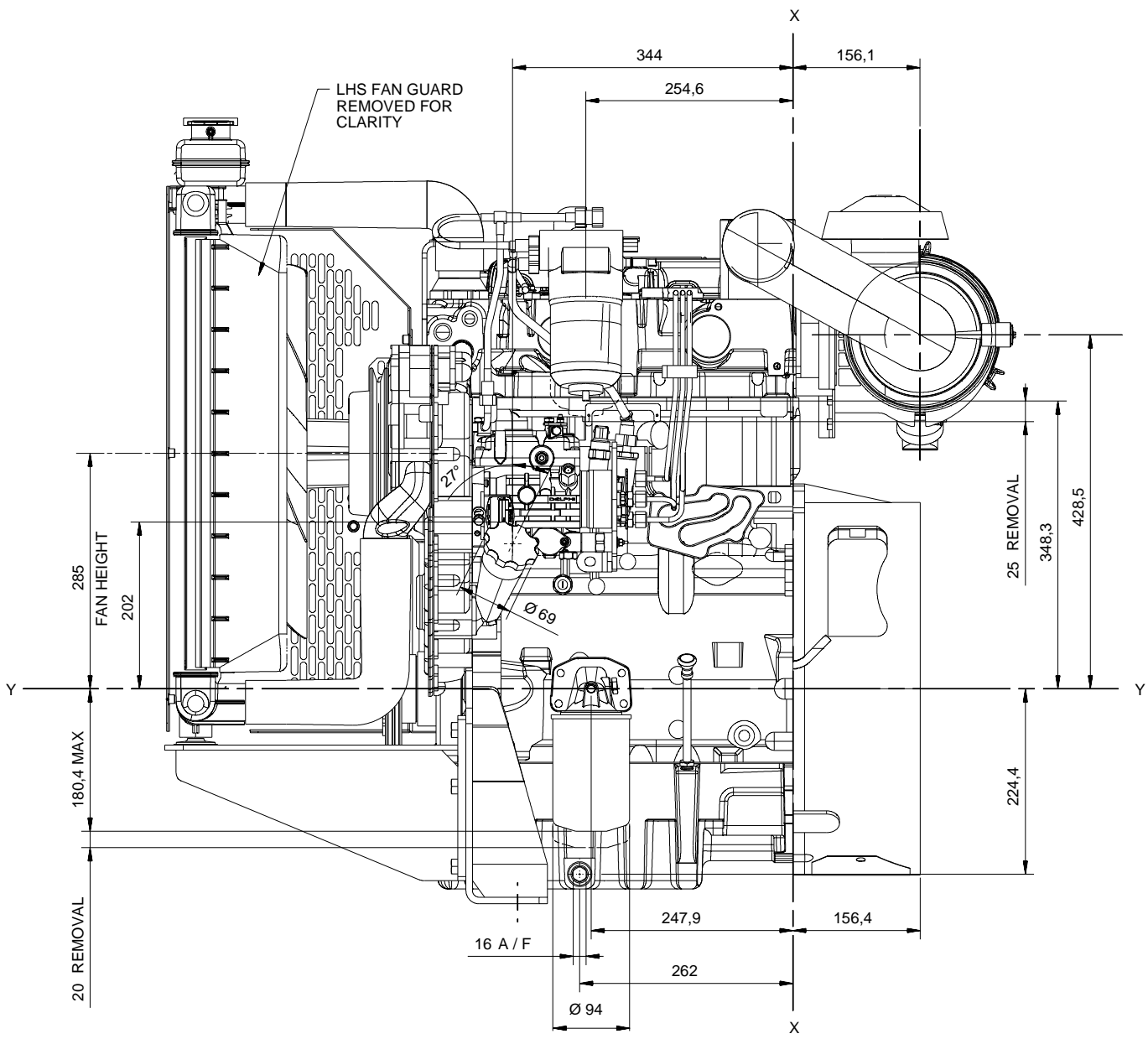

1103C-33 G2 Electropak - left side view



1103C-33 G2 ElectropaK - right side view

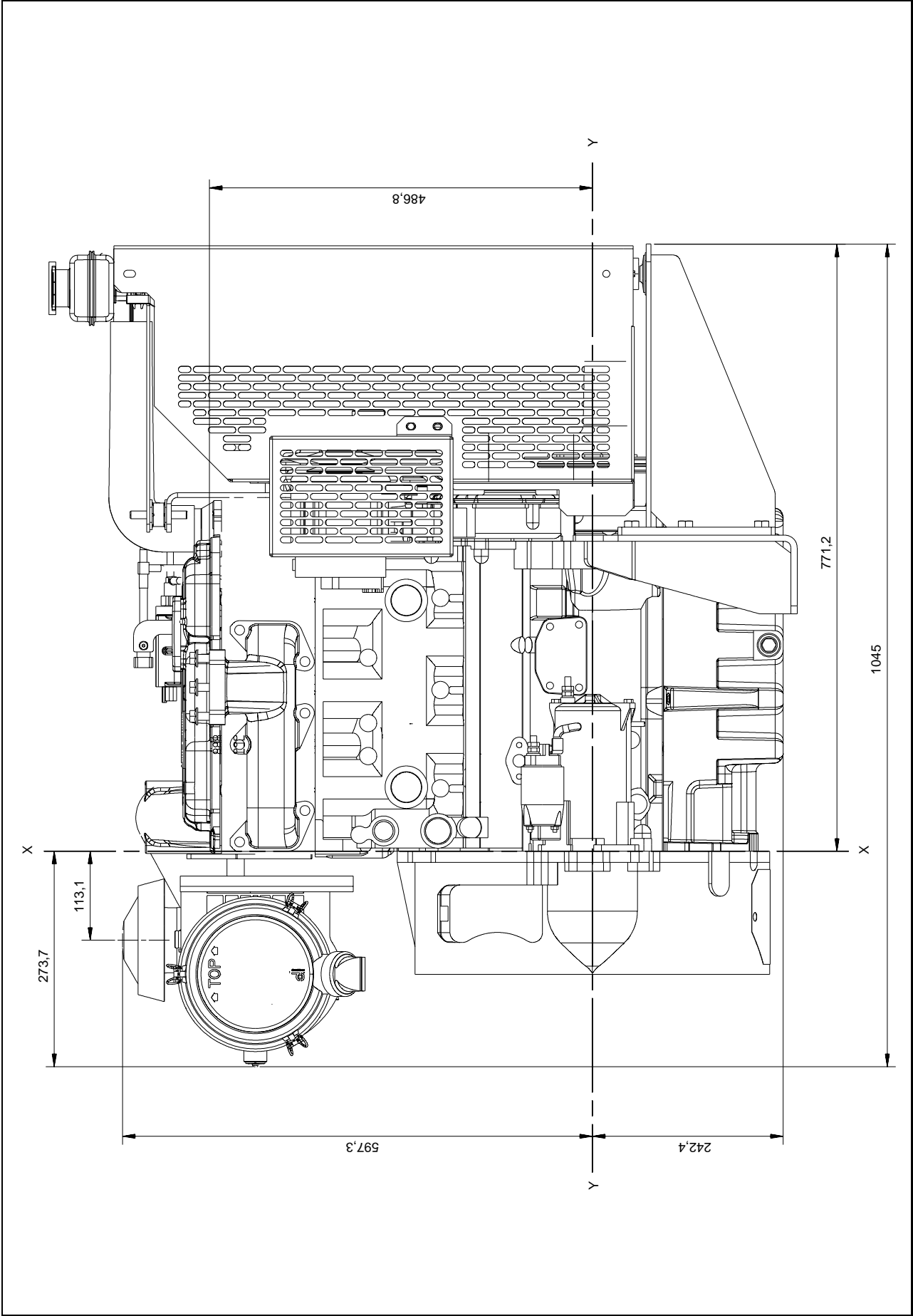

1103C-33 G2 ElectropaK - rear view

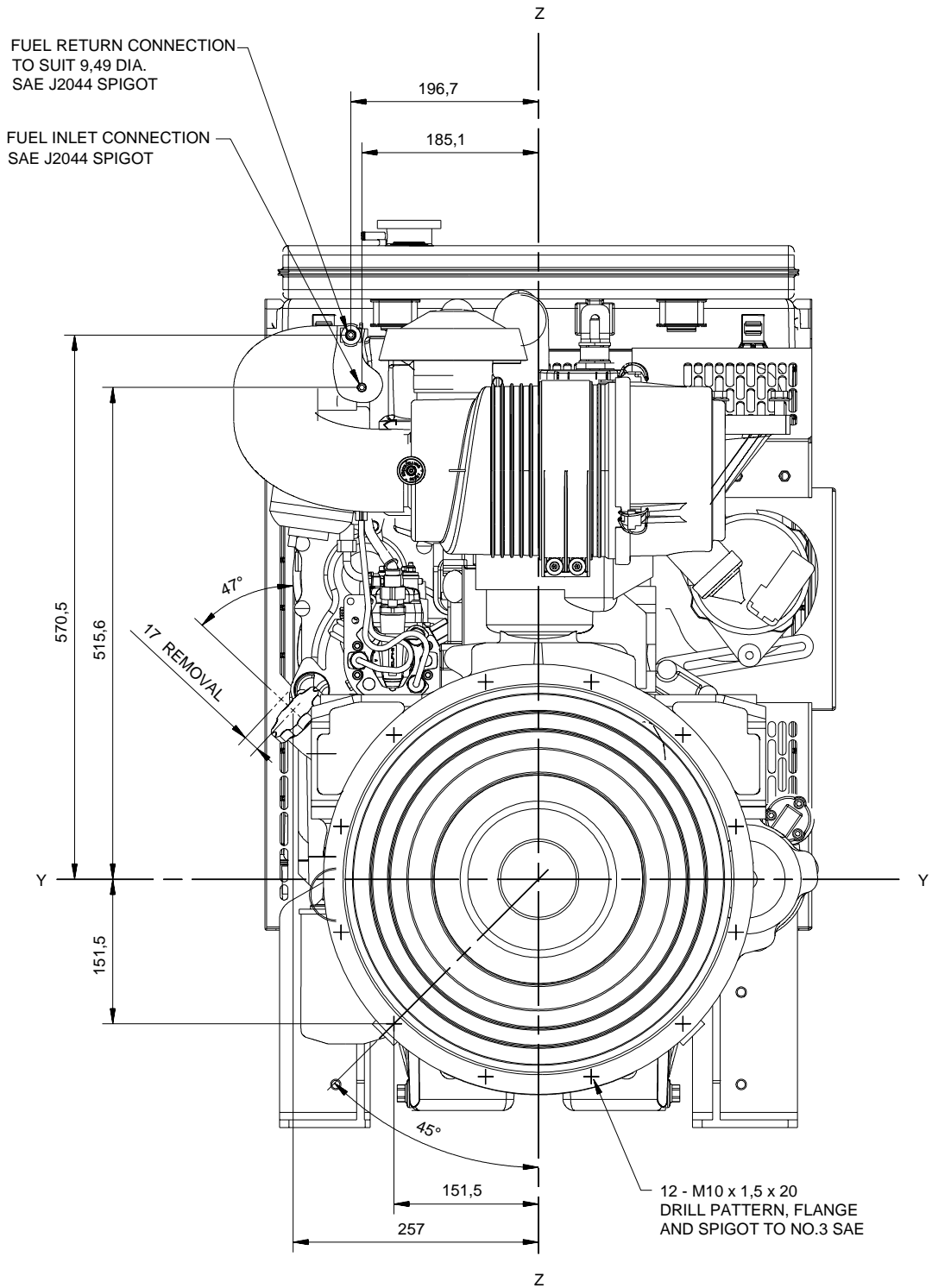

## Cooling system

### Radiator

-face area... 0,276 m<sup>2</sup>  
 -rows and materials ... single row, Aluminium  
 -matrix density and material... Aluminium, 12,7 fins/Inch  
 -width of matrix... 526 mm  
 -height of matrix . 524 mm  
 -pressure cap setting . 107 kPa

### Fan

-diameter ... 457 mm  
 -drive ratio ... 0-85:1  
 -number of blades... 7  
 -material ... Composite  
 -type ... Pusher

### Coolant

Total system capacity:  
 -with radiator ... 10,2 ltrs  
 -without radiator . 4,4 ltrs  
 Maximum top tank temperature ... 110 °C  
 Thermostat operation range... 82 - 93 °C  
 Recommended coolant:  
 50% ethylene glycol with a corrosion inhibitor (BS 658 :1992 or MOD AL39) and 50% clean fresh water.

## Electrical system

-type ... Negative ground  
 Alternator  
 -voltage ... 12 V  
 -output ... 65 amps  
 Starter motor  
 -voltage ... 12 V  
 -power ... 3 kW  
 Number of teeth on flywheel ... 126  
 Stop solenoid (maximum)  
 -pull in current @ -25 °C <sup>(1)</sup> ... 10 amps  
 -hold in current @ -25 °C <sup>(1)</sup> ... 10 amps  
 Engine stop solenoid... 12 V  
 1. All leads to rated at 10 amps minimum

### Cold start recommendations

Minimum required cranking speed . 80 rev/min

### Starter specification

Starter motor type	Minimum starting temperature		Minimum battery type for SAE lubricating oil viscosity			
	°C	°F	15W	10W	5W	0W
12 volt 3.0 kW	-5	23	1 x A			
	-15	5		1 x A		
	-20	-4			1 x B	
	-25	-13				1 x B

### Battery specifications

Commercial ref number	Perkins Code	Battery Minimum performance		
		BS 3911	SAEJ537	DIN 43539.2
643	A	440	660	400
647	B	510	770	465
069	D	340	540	300
655	E	570	810	490

## Exhaust system

Maximum back pressure  
 -1500 rev/min ... 12 kPa  
 -1800 rev/min ... 15 kPa  
 Exhaust outlet size ... 56 mm

## Fuel system

Type of injection ... direct  
 Fuel injection pump ... DP210  
 Fuel atomiser... multi-hole  
 Nozzle opening pressure ... 29,0 MPa

### Fuel lift pump

Type ... electrical  
 -flow/hour ... 120 - 150 l/h  
 -pressure . 30 - 75 kPa  
 Maximum suction head (with clean filter)  
 ... 17 kPa at 1.7 m using 8 mm dia bore pipe  
 Maximum static pressure head  
 ... 30 kPa at 2.0 m using 8 mm dia bore pipe

### Governor type

Speed control for diesel to conform to:  
 Electronic governor ... ISO 8528, Class G3  
 Mechanical governor... ISO 8528, Class G2

### Fuel specification

Fuel specification	BS2869 1998 Class A2 or BS EN590
--------------------	----------------------------------

### Fuel consumption

Load	Type of operation and application			
	1500 rev/min		1800 rev/min	
	g/kwhr	litres/hr	g/kwhr	litres/hr
110%	243	8,7	253	10,1
100%	243	7,8	254	9,1
75%	253	6,1	264	7,1
50%	262	4,2	274	4,9
25%	312	2,5	357	3,2

**Induction system**

**Maximum air intake restriction**

- clean filter . . . . . 3 kPa
- dirty filter . . . . . 6,6 kPa
- air filter type . . . . . 2 stage cyclonic/paper element

**Lubrication system**

**Lubricating oil capacity**

- total system . . . . . 8,3 litres
  - sump minimum . . . . . 6,2 litres
  - sump maximum . . . . . 7,8 litres
- Maximum engine operating angles:
- front up, front down, right side or left side. . . . . 25°

**Lubricating oil pressure**

- relief valve opens . . . . . 415 - 470 kPa
- at maximum no-load speed . . . . . 276 - 414 kPa
- oil temperature at normal operating conditions . . . . . 110 °C
- max continuous oil temperature (in rail) . . . . . 125 °C
- oil consumption at full load as a % of fuel consumption . . . . . 0,15 %

**Recommended SAE viscosity**

A single or multigrade oil must be used which conforms to API-CG4/CH4 or ACEA-E3/E5, see illustration below:

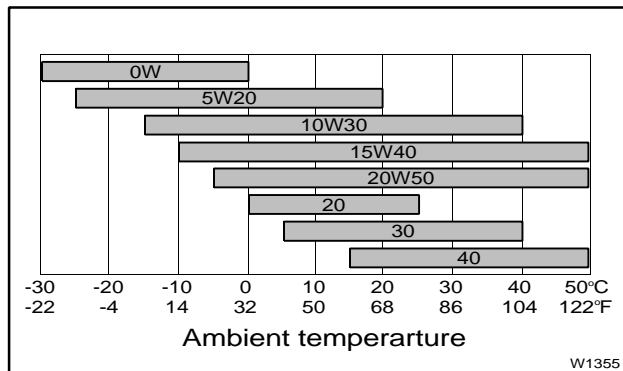

**Mountings**

Maximum static bending moment at rear face of block . . . . . 791 Nm

**Load acceptance - cold engine**

Initial load application when engine reaches rated speed (15 seconds max after engine starts to crank)			
	Units	1500 rev/min	1800 rev/min
Prime Power	%	90	90
Load	kW kWe	21,6	24,3
Transient frequency deviation	%	< 10	< 10
Frequency recovery	seconds	< 5	< 5

The above complies with requirements of classification 3 & 4 of ISO 8528-12 and G2 operating limits stated in ISO 8528-5. The above figures were obtained under the test conditions as follows:

- Engine block temperature . . . . . 45 °C
  - Alternator efficiency . . . . . TBA %
  - Minimum ambient temperature . . . . . 10 °C
- Isochronous governing:**
- typical alternator inertia . . . . . TBA kgm<sup>2</sup>

All tests were conducted using an engine installed and services to Perkins Engines Company Limited recommendations

The information given in this document is for guidance only.



**Perkins Engines Company Limited**  
 Peterborough PE1 5NA United Kingdom  
 Telephone +44 (0) 1733 583000  
 Fax +44 (0) 1733 582240  
 www.perkins.com

All information in the document is substantially correct at the time of printing but may be subsequently altered by the company.

Distributed by