

# Technical Data

## 1100 Series

Gen Set

# 1103A-33TG1

**45,6 kWm @ 1500 rev/min**

**53,9 kWm @ 1800 rev/min**

### Basic technical data

Number of cylinders . . . . . 3  
Cylinder arrangement . . . . . Vertical in-line  
Cycle . . . . . Four stroke  
Induction system . . . . . Turbocharged  
Compression ratio . . . . . 17.25 : 1  
Bore . . . . . 105 mm (4.13 in)  
Stroke . . . . . 127 mm (4.99 in)  
Cubic capacity . . . . . 3.3 litres  
Direction of rotation . . . . . Clockwise view from front  
Firing order . . . . . 1,2,3  
Total weight (engine only)  
-dry . . . . . 420 kg  
-wet . . . . . 438 kg

### Overall dimensions

-height . . . . . 951 mm (37.44 in)  
-length . . . . . 1049 mm (41.29 in)  
-width (including mounting brackets) . . . . . 634 mm (24.96 in)

### Moment of inertia (mk<sup>2</sup>)

Engine:  
- longitudinal . . . . . 25 kgm<sup>2</sup>  
- horizontal . . . . . 42 kgm<sup>2</sup>  
- axial . . . . . 25 kgm<sup>2</sup>  
Flywheel (polar) . . . . . 1.14 kgm<sup>2</sup>

### Centre of gravity (wet)

- forward from rear of block . . . . . 215 mm (8.46 in)  
- above centre line of block . . . . . 120 mm (4.72 in)  
- offset of RHS of centre line . . . . . 25 mm (0.98 in)

### Performance

Steady state speed stability at constant load:  
G2 . . . . . ± 0.75%

**Note:** All data based on operation to ISO 3046/1, BS 5514 and DIN 6271 standard reference conditions.

### Test conditions

Air temperature . . . . . 25 °C  
Barometric pressure . . . . . 100 kPa  
Relative humidity . . . . . 30%

### Sound level

Overall sound pressure level (cooling pack and air cleaner fitted):  
- at 1500 rev/min . . . . . 88,2 dBA  
- at 1800 rev/min . . . . . 92,1 dBA

Sound pressure level from the mean of 4 microphones at the front, left, right and above the engine. Exhaust was piped away out of the test cell.

If the engine is to operate in ambient conditions other than those of the test conditions, suitable adjustments must be made for these changes. For full details, contact Perkins Technical Service Department.

## General installation

Designation	Units	Type of Operation and Application			
		Prime	Stand-by	Prime	Stand-by
		50 Hz	50 Hz	60 Hz	60 Hz
Gross engine power	kWm	42,2	46,5	50,5	55,6
Brake mean effective pressure	kPa (lbf/in <sup>2</sup> )	1023 (148.3)	1128 (163.6)	1020 (147.9)	1124 (163.0)
Mean piston speed	m/s (ft/s)	6,35 (20.8)	6,35 (20.8)	7,62 (25.0)	7,62 (25.0)
ElectropaK net engine power	kWm	41,3	45,6	48,8	53,9
Engine coolant flow 35 kPa restriction	l/min (UK gal/min)	125,5 (27.6)	125,5 (27.6)	151,0 (33.2)	151,0 (33.2)
Combustion air flow	m <sup>3</sup> /min (ft <sup>3</sup> /min)	2,9 (102.4)	3,1 (109.4)	3,7 (130.6)	3,9 (137.7)
Exhaust gas flow (max)	m <sup>3</sup> /min (ft <sup>3</sup> /min)	7,0 (247.2)	7,7 (271.9)	8,8 (310.7)	9,5 (335.4)
Exhaust gas temperature (max) in manifold	°C (°F)	492 (917.6)	537 (999.6)	510 (950.0)	551 (1023.8)
Cooling fan air flow	m <sup>3</sup> /min (ft <sup>3</sup> /min)	53,0 (1871.6)	53,0 (1871.6)	70,0 (2472.0)	70,0 (2472.0)
Overall thermal efficiency	%	39,8	38,7	39,3	39,1
Typical genset electrical unit (0.8 pf 25° C)	kWe	36,0	39,7	42,5	46,9
	kVA	45,0	49,6	53,1	58,7
Assumed alternator efficiency	%	87%			
<b>Energy balance</b>					
Power in fuel (Fuel heat of combustion)	kW (Btu/min)	106,0 (6033.4)	120,0 (6830.3)	129,0 (7342.6)	142,0 (8082.5)
Power output (gross)	kW (Btu/min)	42,2 (2402.0)	46,5 (2646.7)	50,5 (2874.4)	55,6 (3164.7)
Power to cooling fan	kW (Btu/min)	0,9 (51.2)	0,9 (51.2)	1,7 (96.7)	1,7 (96.7)
Power output (net)	kW (Btu/min)	41,3 (2350.7)	45,6 (2595.5)	49,0 (2789.0)	53,9 (3067.9)
Power to coolant and lubricating oil	kW (Btu/min)	26,0 (1479.9)	30,0 (1707.5)	31,0 (1764.5)	34,0 (1935.2)
Power to exhaust	kW (Btu/min)	30,0 (1707.5)	35,0 (1992.1)	39,0 (2219.8)	43,0 (2447.5)
Power to radiation	kW (Btu/min)	7,0 (398.4)	8,0 (455.3)	8,0 (455.3)	9,0 (512.2)

**Caution:** The airflows shown in this table will provide acceptable cooling for an open power unit operating in ambient temperatures of up to 53 °C (127 °F) or 46 °C (114.8 °F) if a canopy is fitted. If the power unit is to be enclosed totally, a cooling test should be done to check that the engine cooling is acceptable. If there is insufficient cooling, contact Perkins Technical Service Department.

## Cooling system

### Radiator

- face area ... 0.276 m<sup>2</sup> (2.97 ft<sup>2</sup>)
- rows and materials... single row aluminium
- matrix density and material... Aluminium 12.5 fins/inch
- width of matrix... 526 mm (20.7 in)
- height of matrix... 524 mm (20.6 in)
- pressure cap setting... 107 kPa

### Fan

- diameter... 457 mm (18 in)
- drive ratio... 0.85 : 1
- number of blades... 7
- material... Composite
- type... Pusher

### Coolant

- Total system capacity
- with radiator... 10.2 l (21.5 pt)
- without radiator... 4.4 l (9.2 pt)
- Maximum top tank temperature... 110 °C (230 °F)
- Thermostat operating range... 82 - 93 °C (180 - 199 °F)
- Recommended coolant: 50 % ethylene glycol with a corrosion inhibitor (BS 658 : 1992 or MOD AL39) and 50% clean fresh water.

## Electrical system

- Type... Negative ground
- Alternator voltage... 12 V
- Alternator output... 65 amps
- Starter motor voltage... 12 V
- Starter motor power... 3 kW
- Number of teeth on flywheel... 126
- Pull in current of starter motor solenoid... 60 amps
- Hold in current of starter motor solenoid... 15 amps
- Engine stop solenoid... 12 V
- Stop solenoid (minimum)
- pull in current... 10 amps
- hold in current... 10 amps

### Cold start recommendations

- Minimum cranking speed... 105 rev/min

### Starter specification

Starter motor type	Minimum starting temperature	Lubricating oil viscosity SAE / battery type - values in CCA			
		15W/40	10W/40	5W/40	5W/30
12 volt 3.0 kW	°C (°F)				
	-10 (14)	1 x 660			
	-15 (5) *		1 x 660		
	-20 (-4) *			1 x 660	
	-25 (-13) *				2 x 570

\* - Glow plug start aid fitted.

**Note:** CCA - Cold Cracking Amps to SAEJ537.

### Notes:

- Battery capacity is defined by the 20 hour rate
- If a change to a low viscosity oil is made, the cranking torque necessary at lower ambient temperatures is much reduced. The starting equipment has been selected to take advantage of this. It is important to change the appropriate multigrade oil in anticipation of operating in low ambient temperatures.
- Breakaway current is dependent on battery capacity available. Cables should be capable of handling the transient current which may be up to double the steady cranking current.

## Exhaust system

- Maximum back pressure
- 1500 rev/min... 10 kPa
- 1800 rev/min... 15 kPa
- Exhaust outlet size... 56 mm (2.2 in)

## Fuel System

- Type of injection... Direct
- Fuel injection pump... Rotary
- Fuel atomiser... Multi-hole
- Nozzel opening pressure... 29,0 MPa (290 bar)

### Fuel lift pump

- Type... Electrical
- flow/hour... 120 - 150 l/h (211 - 264 pt/m)
- pressure... 30 - 75 kPa (4.4 - 10.9 psi)
- Maximum suction head:
- 1500 rev/min... 20 kPa

### Governor type

- Electronic governor (optional)... Woodward LCG2
- Mechanical and electronic governor speed control to... ISO 8528, G2

### Fuel specification

Fuel Specification	European RF75-T-96 / DIN EN590 / BS2869 class A2
Density (kg/l @ 15 °C)	0,835 - 0,845
Viscosity (mm <sup>2</sup> /s @ 40 °C)	2,5 - 3,5
Sulphur content (%)	0,1 - 0,2
Cetane number	45 - 50

### Fuel consumption litres/hour (UK gals/hr)

Speed	Power rating				
	110%	100%	75%	50%	25%
1500	12,0 (2.6)	10,7 (2.3)	8,2 (1.8)	5,7 (1.2)	3,4 (0.7)
1800	14,3 (3.1)	12,9 (2.8)	9,9 (2.1)	7,1 (1.5)	4,3 (0.9)

## Induction system

### Maximum air intake restriction

- clean filter... 5 kPa
- dirty filter... 8 kPa
- air filter type... Dry

## Lubrication system

### Lubricating oil capacity

- Total system... 8,3 l (17.5 pt)
- Sump minimum... 6,2 l (13.1 pt)
- Sump maximum... 7.8 l (16.4 pt)
- Maximum engine operating angles:

- front up, front down, right side or left side... 25°

### Lubricating oil pressure

- relief valve opens... 415 - 470 kPa
- at maximum no-load speed... 276 - 414 kPa
- Max continuous oil temperature... 125 °C (257 °F)
- Oil consumption at full load as a % of fuel consumption... 0.15%

1103A-33TG1 ElectropaK - left view

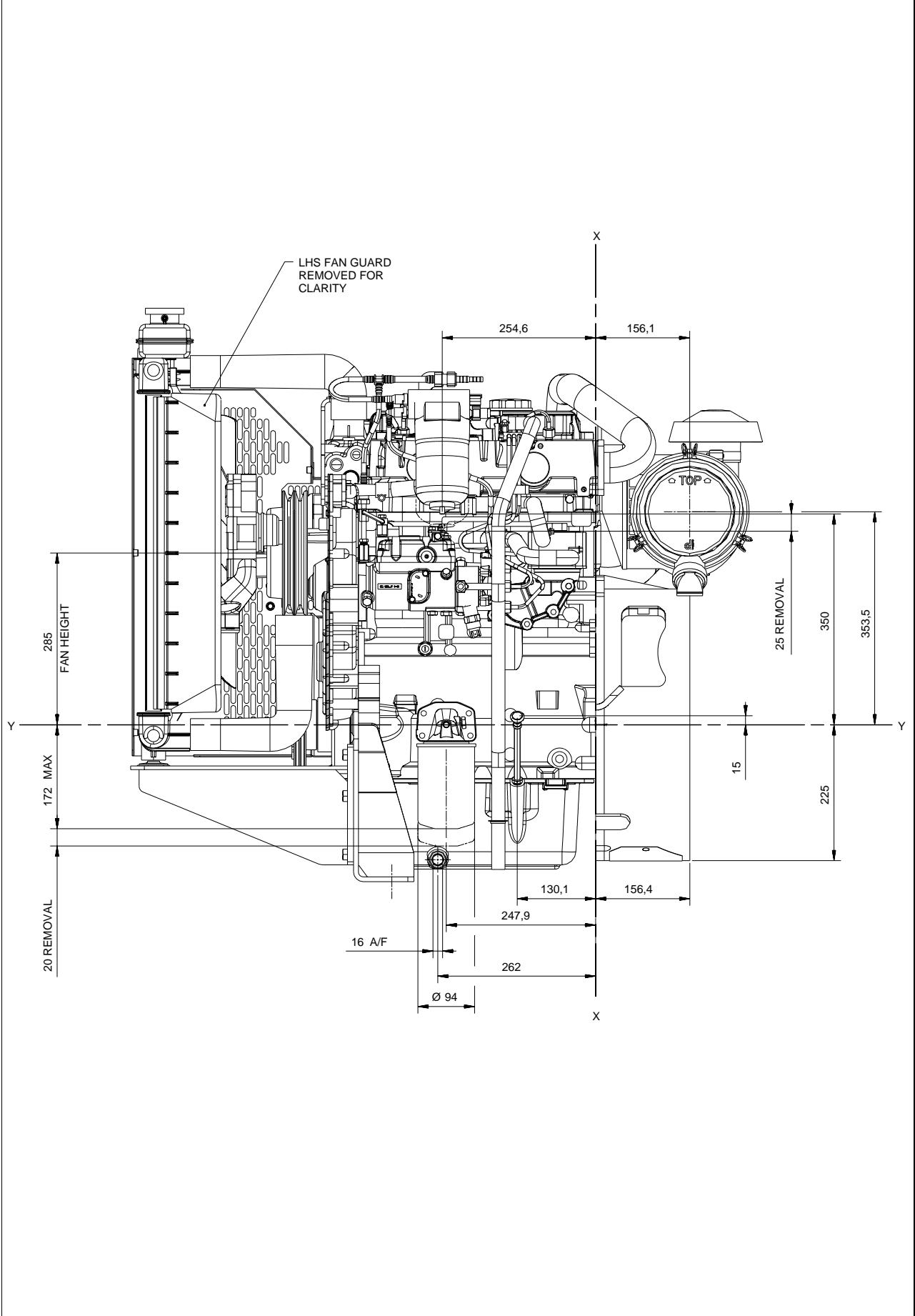

# 1103A-33TG1 ElectropaK - front view

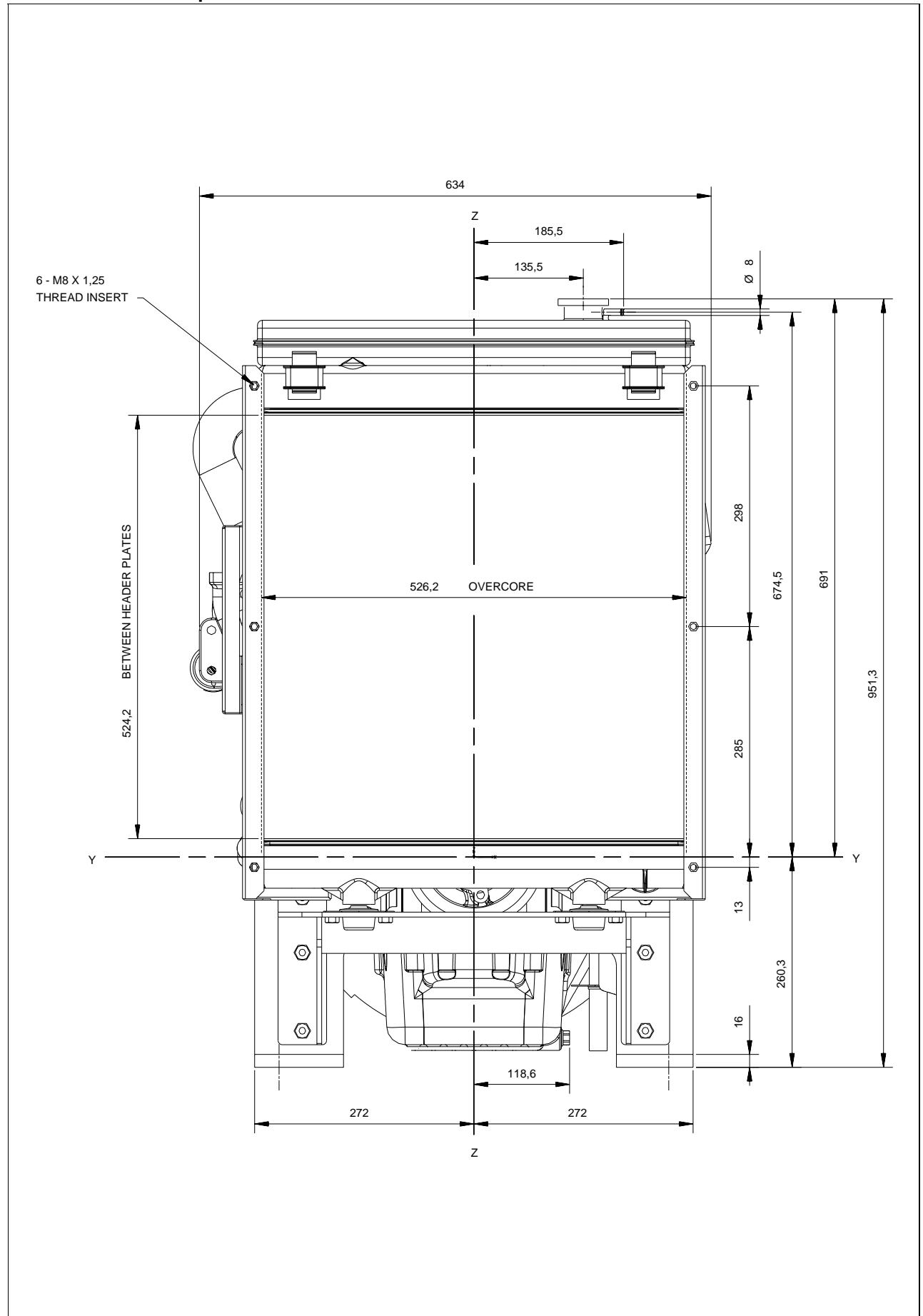

1103A-33TG1 ElectropaK - right view

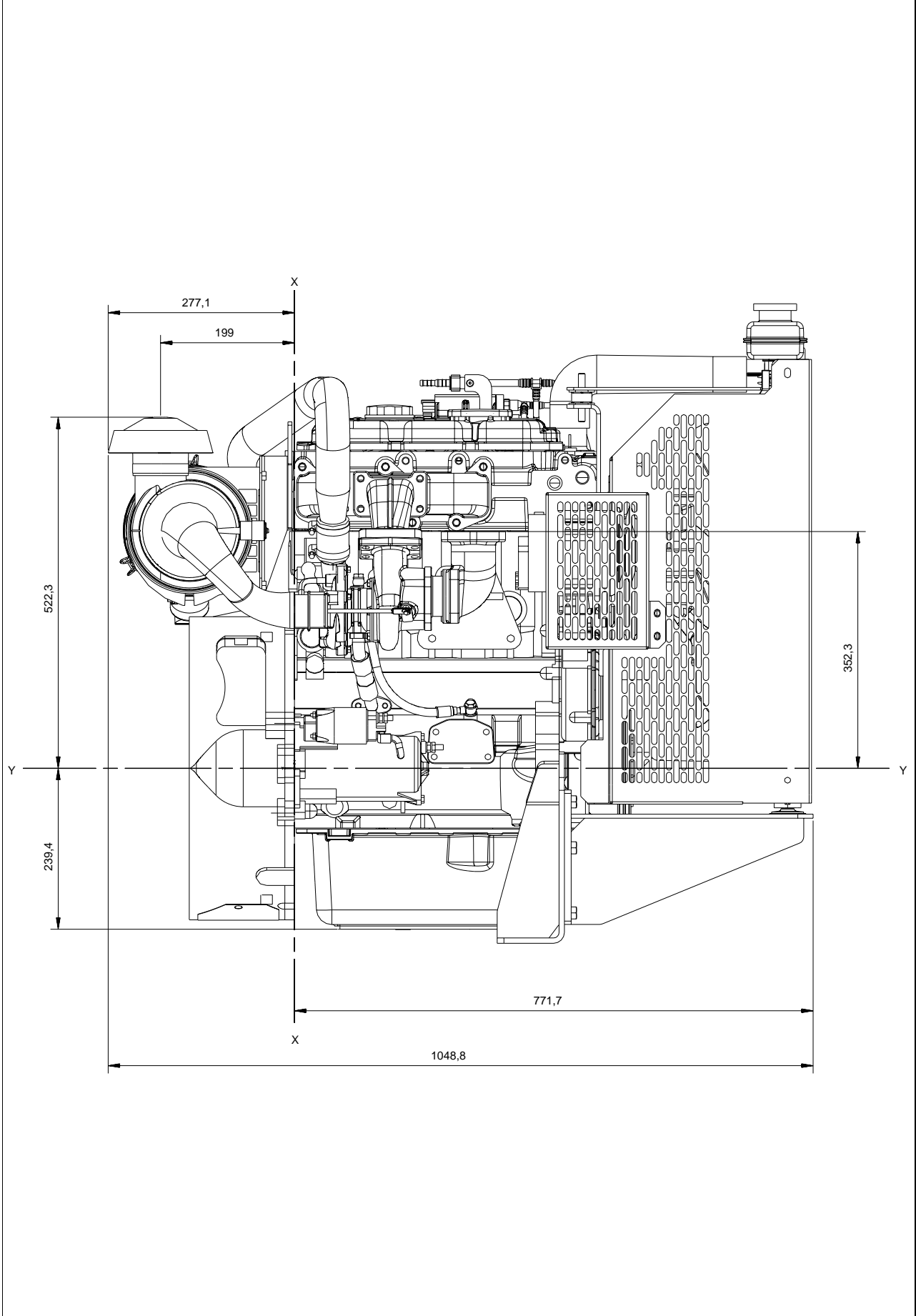

# 1103A-33TG1 ElectropaK - rear view

FUEL RETURN CONNECTION TO  
SUIT DIA. 8 OR DIA. 10 HOSE.

FUEL INLET CONNECTION  
TO SUIT DIA. 8 HOSE

DEUTSCH DT02P  
CONNECTOR

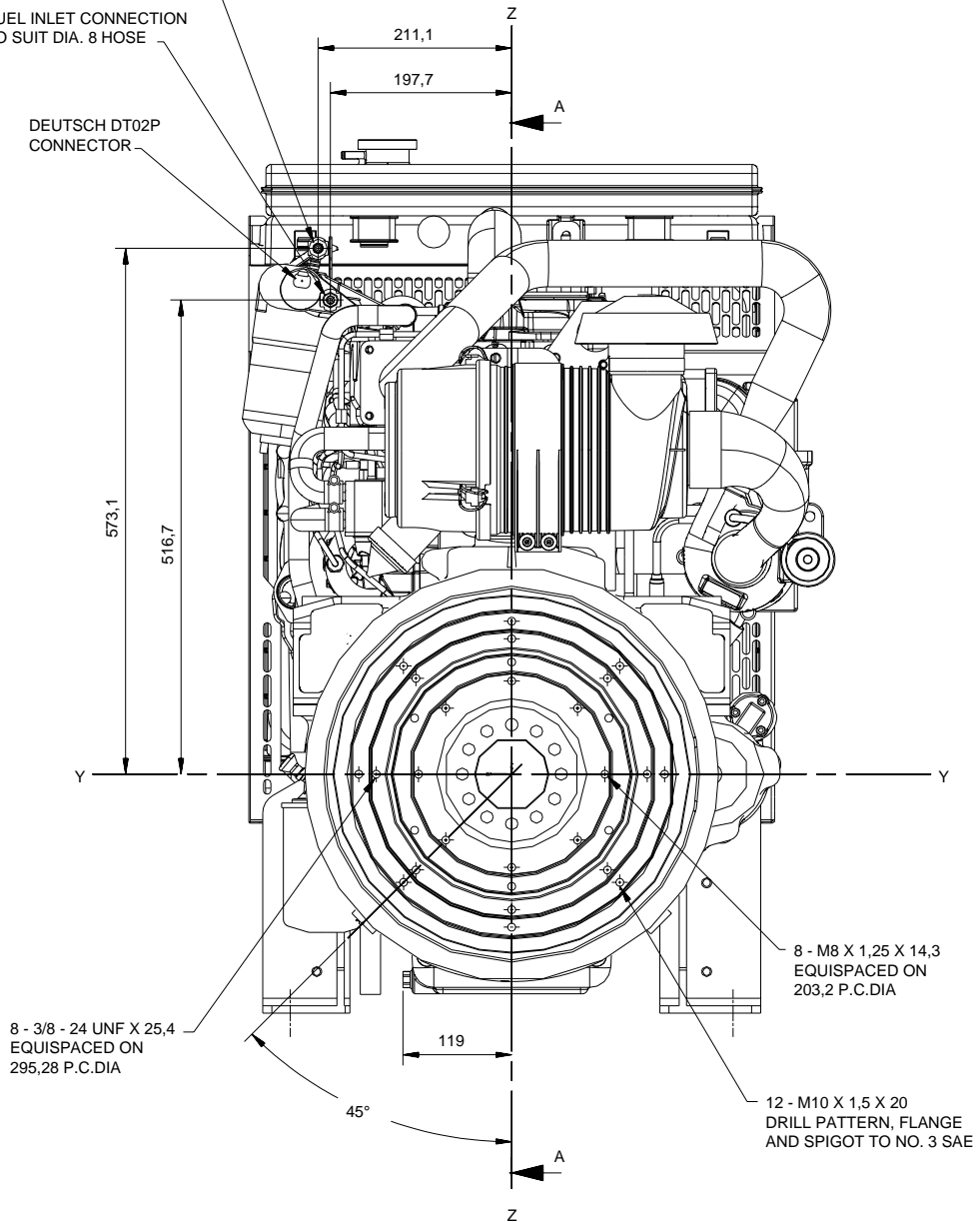

**Recommended SAE viscosity**

A single or multigrade oil must be used which conforms to API-CG4 / CH4, see illustration below:

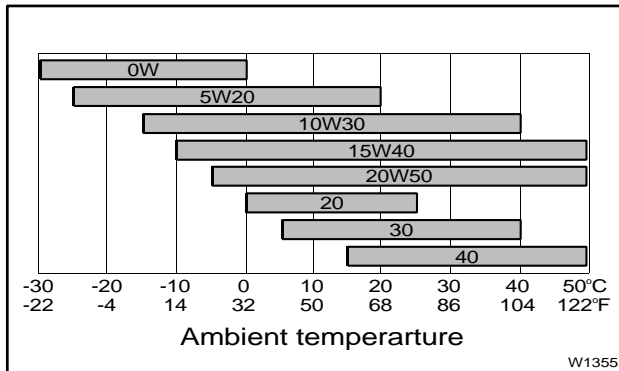

**Mountings**

Maximum static bending moment at rear face of block ... 791 Nm (583 lb/ft)

**Load Acceptance**

Initial load application when engine reaches rated speed (15 seconds max after engine starts to crank)			
	Units	1500 rev/min	1800 rev/min
Prime Power	%	90	90
Load	kWm/ kWe	38,0 (32.3)	45,5 (38.2)
Transient frequency deviation	%	< 10	< 10
Frequency recovery	seconds	< 5	< 5

The above complies with requirements of classification 3 & 4 of ISO 8528-12 and G2 operating limits stated in ISO 8528-5. The above figures were obtained under the test conditions as follows:

Engine block temperature ... 105 °C  
 Alternator efficiency ... 87%  
 Minimum ambient temperature ... 10 °C

**Isochronous governing:**

- typical alternator inertia ... 0.364 kgm²

All tests were conducted using an engine installed and services to Perkins Engines Company Limited recommendations

**The information given in this document is for guidance only.**

**@ Perkins®**

**Perkins Engines Company Limited**  
 Peterborough PE1 5NA United Kingdom  
 Telephone +44 (0) 1733 583000  
 Fax +44 (0) 1733 582240  
 www.perkins.com

All information in the document is substantially correct at the time of printing but may be subsequently altered by the company.

Distributed by